



15370 Barranca Parkway
Irvine, CA 92618



FARGO® C50 Printer

SERVICE MANUAL

PLT-01278 Rev 1.1

August 2013

© 2013 HID Global Corporation/ASSA ABLOY AB. All rights reserved.

HID GLOBAL CONFIDENTIAL AND/OR PROPRIETARY INFORMATION. This document contains confidential and/or proprietary information, which may not be duplicated, published, disseminated or disclosed, or used for any purpose, without the written consent of HID Global Corporation. If you are an unintended recipient of this information or are unwilling to accept the above restrictions, please immediately return this document to HID Global Corporation, 15370 Barranca Pkwy, Irvine, CA 92618-3106..

Contents

1	Introduction	4
1.1	Safety Messages (review carefully)	4
1.2	Tools need for Card Printer repair- replacement procedures	6
2	Cover Removal Procedures	7
2.1	Remove/Replace Printer Covers	7
2.2	Remove/Replace Printer Top Cover/PCB display	10
3	Parts Replacement- Printer	11
3.1	Remove/Replace the Mainboard	11
3.2	Remove/Replace the Stepper Drive Motor (D930027) Remove/Replace Stepper Belt F000424 Remove/Replace Pulley D900430	13
3.3	Remove/Replace the Mag Roller (D930122)	19
3.4	Remove/Replace the Output Roller (D930123) Remove/Replace Pinch Roller-spring (D920013-F000338)	22
3.5	Remove/Replace the Platen Roller (D930120) & Pulley/Gear (D900429)	24
3.6	Remove/Replace the Lift Pinch Roller Assembly (D930137), Remove/Replace Pinch Lift Bracket (D930136)	27
3.7	Remove/Replace the Cleaning Roller (D930121), Remove/Replace Input Feed Lever (D930132), Remove/Replace Input Lever Gear (D930164)	32
3.8	Remove/Replace Supply Spindle RFID Motor (D930015-01)	34
3.9	Remove/Replace Ribbon Take-Up Motor (D930014)	36
3.10	Remove/Replace Encoder Sensor (A930514) for RFID Supply Spindle/ Cable (D930605), Remove/Replace PCB board (A000365-01)	38
3.11	Remove/Replace the PCB board (A000365-01)	42
3.12	Remove/Replace Ribbon Sensor (D930016)	43
3.13	Remove/Replace Card Path/Cover Sensor (D930613)	46
3.14	C50 Printhead procedure	48
4	Appendix D Printer Mainboard connections	60
5	Appendix E Engineering Drawings	63

Revision History

Date	Description	Document Version
6-2013	C50 Card Printer Service Manual	1.0
8-2013	C50 Card Printer Service Manual	1.1 added new mainboard pictures

North America

15370 Barranca Parkway,
Irvine, CA 92618,
USA

866 607-7339, #6

M-F 7am-6pm CST

Europe, Middle East and Africa

Phoenix Road,
Haverhill, Suffolk CB9 7AE,
England

+44 1440 711 822

M-TH 8:30 - 17:30 GMT
(FR 8:30 - 17:00)

Asia Pacific

19/F 625 King's Road,
North Point, Island East,
Hong Kong

+852 3160 9833

M-F 9am – 6pm GMT +8

Brazil

Av Guido Caloi 1985 Prédio 18
São Paulo – SP,

CEP : 05802-140

55 11 5514-7110

M-F 9am – 6pm ATC

support.hidglobal.com

www.hidglobal.com

HID GLOBAL, HID, the HID logo, and FARGO are the trademarks or registered trademarks of HID Global Corporation, or its licensors, in the U.S. and other countries.

1 Introduction

The service manual serves to inform the technician about the C50 Card Printer parts replacement procedures.

Important: These procedures can only be performed by authorized service personnel. Estimated repair time may vary according to the technicians experience.



Caution: Turn OFF the Printer and unplug the power cord from the Printer.
ESD precautions are necessary when handling electronics assemblies



Danger: Wear proper eye protection to perform the procedures in this section.

1.1 Safety Messages (review carefully)

The purpose of this section is to provide the User with specific replacement procedures for the Card Printer. Please review standard precautions (to take) while performing these replacement procedures.

Symbol	Critical Instructions for Safety purposes
<p>Danger:</p> 	<p>Failure to follow these installation guidelines can result in death or serious injury.</p> <p>Information that raises potential safety issues is indicated by a warning symbol (as shown to the left).</p> <p>To prevent personal injury, refer to the following safety messages before performing an operation preceded by this symbol.</p> <p>To prevent personal injury, always remove the power cord prior to performing repair procedures, unless otherwise specified.</p> <p>To prevent personal injury, make sure only authorized service personnel perform these procedures.</p>

Symbol	Critical Instructions for Safety purposes
<p>Caution:</p> 	<p>This device is electrostatically sensitive. It can be damaged if exposed to static electricity discharges.</p> <p>Information that raises potential electrostatic safety issues is indicated by a warning symbol (as shown to the left).</p> <p>To prevent equipment or media damage, refer to the following safety messages before performing an operation preceded by this symbol.</p> <p>To prevent equipment or media damage, observe all established Electrostatic Discharge (ESD) procedures while handling cables in or near the Circuit Board and Printhead Assemblies</p> <p>To prevent equipment or media damage, always wear an appropriate personal grounding device (e.g., a high quality wrist strap grounded to avoid potential damage).</p> <p>To prevent equipment or media damage, always remove the Ribbon and Cards from the Printer before making any repairs, unless otherwise specified.</p> <p>To prevent equipment or media damage, take jewelry off of fingers and hands, as well as thoroughly clean hands to remove oil and debris before working on the Printer.</p>

1.2 Tools need for Card Printer repair- replacement procedures

T10 Torx screwdriver

E Clip tool

Small flathead screwdriver



Needle Nose Pliers

(NOTE: HID Global offers a kit that contains many of the tools needed to repair the printers.



Part Number 085627)

2 Cover Removal Procedures

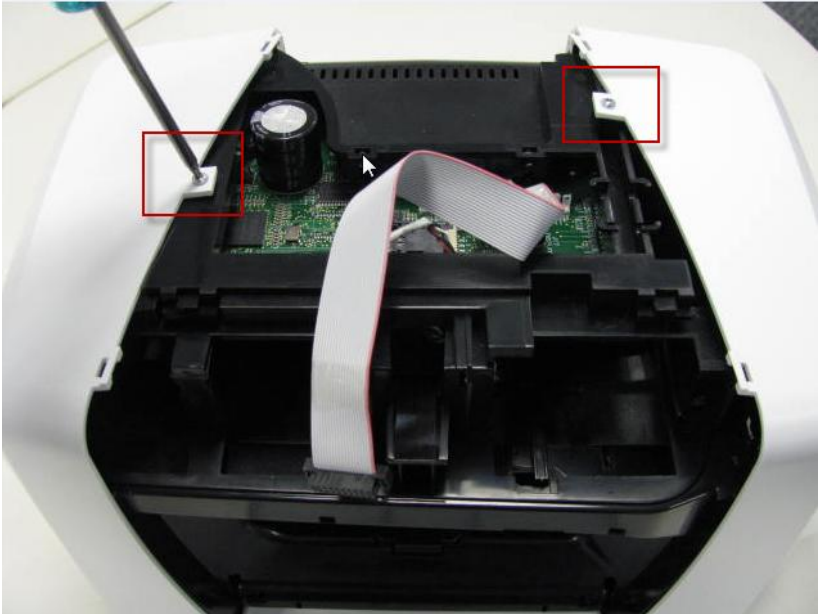
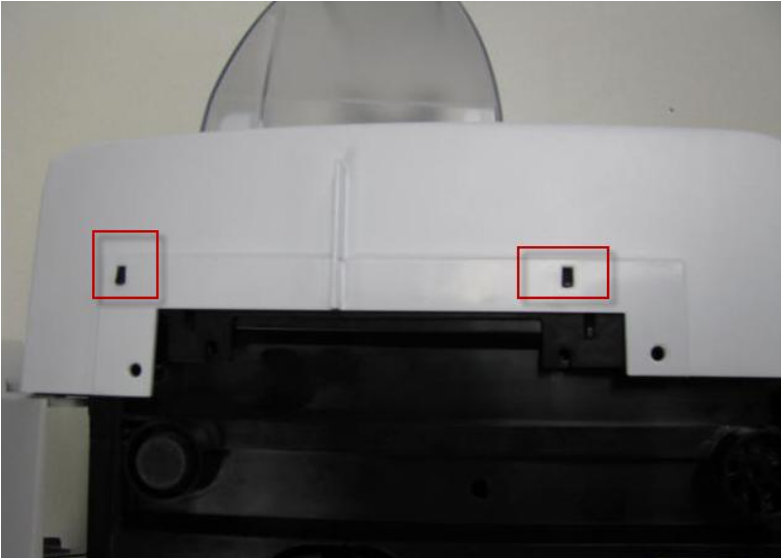

2.1 Remove/Replace Printer Covers

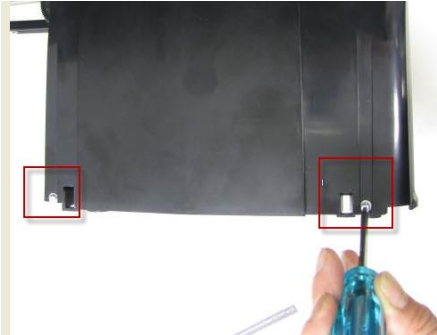
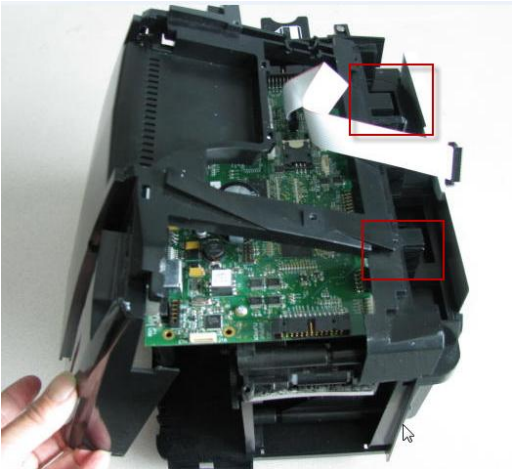
	<p>Tools needed: T10 Torx screwdriver</p> <p>Estimated Repair Time: 15 minutes</p> <p>Preparation:</p> <p>Important: This procedure can only be performed by authorized service personnel.</p> <table border="0"> <tr> <td>Top Cover/PCB Assy</td> <td>D930034-03</td> </tr> <tr> <td>Front Door</td> <td>D930265-03</td> </tr> <tr> <td>Left Cover</td> <td>D930263-04</td> </tr> <tr> <td>Right Cover</td> <td>D930264-03</td> </tr> <tr> <td>Back Cover</td> <td>D930270-01</td> </tr> <tr> <td>Output Bin</td> <td>D930269-01</td> </tr> </table>	Top Cover/PCB Assy	D930034-03	Front Door	D930265-03	Left Cover	D930263-04	Right Cover	D930264-03	Back Cover	D930270-01	Output Bin	D930269-01
Top Cover/PCB Assy	D930034-03												
Front Door	D930265-03												
Left Cover	D930263-04												
Right Cover	D930264-03												
Back Cover	D930270-01												
Output Bin	D930269-01												
Step	Procedure												
1	 <p>Caution: Turn OFF the Printer and unplug the power cord from the Printer.</p>												
2	<p>Open the front door. Locate and remove the 2 screws. (F000178)</p> 												
3	<p>Lift up the top cover and disconnect the display cable (D930607) from the main board. Remove the top cover by flexing the center to disengage the insert tabs.</p>												

Step	Procedure
4	<p>Remove the 2 screws (F000178) that hold the side covers to the frame.</p>  <p>The image shows the internal components of the printer with the top cover removed. A screwdriver is positioned to remove a screw from the left side cover. Two red boxes highlight the screws on both the left and right side covers. A ribbon cable is visible in the center, and a battery is located at the top.</p>
5	<p>Remove both side covers. The input and output hoppers are attached to the side covers. When replacing the side covers, note the frame tabs fit into the cover holes to secure it at the bottom.</p>  <p>The image shows the external view of the printer with the top cover removed. Two red boxes highlight the screws on the left and right side covers. The input and output hoppers are visible on the side covers.</p>

Step	Procedure
6	<p>Remove the outer back cover. Remove the 2 screws at the base of the back cover.</p>  <p>Lift UP the bottom of this cover to release the upper tabs that hold the cover to the frame.</p> 
7	<p>Remove the Front Cover by bending from the center.</p> 
8	<p>Procedure is complete.</p>

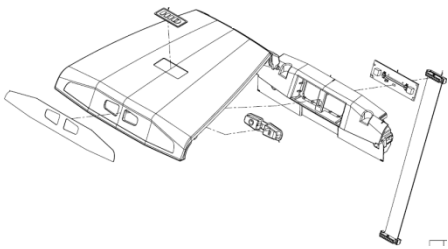
2.2 Remove/Replace Printer Top Cover/PCB display

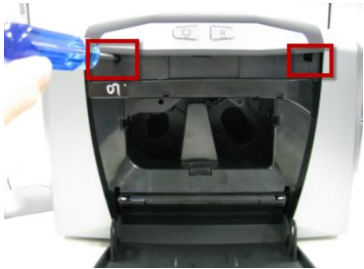
	<p>Tools needed: T10 Torx screwdriver</p> <p>Estimated Repair Time: 15 minutes</p> <p>Preparation:</p> <p>Important: This procedure can only be performed by authorized service personnel.</p> <p>Top Cover/PCB Assy D930034-03</p> <p>Replace complete top cover for the PCB or any part shown. Parts not sold separately.</p>
Step	Procedure
1	 <p>Caution: Turn OFF the Printer and unplug the power cord from the Printer.</p>
2	<p>Open the front door. Locate and remove the 2 screws. (F000178)</p> 
3	<p>Lift up the top cover and disconnect the display cable (D930607) from the main board. Remove the top cover by flexing the center to disengage the insert tabs.</p>
4	<p>Replace with new top cover, reconnect the cable.</p>
5	<p>Procedure is complete</p>

3 Parts Replacement- Printer

3.1 Remove/Replace the Mainboard

Mainboard Part Number Printer Part Number

PCA-00031 NAM	051975 (NM)
PCA-00032 APAC/CCC	051976/ 051977 (AP)
PCA-00033 LAM	051978 (LM)
PCA-00034 BRAZIL	051979 (BR)
PCA-00035 WE	051980 (WE)
PCA-00036 EE/MEA	051981 (EE)

IMPORTANT NOTE: The localized Firmware allows for the use of specialized ribbons. Order the correct mainboard for your location by checking the Printer part number.

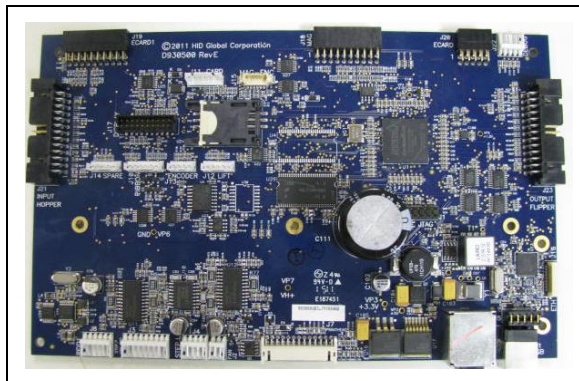

Tools needed: T10 Torx screwdriver

Estimated Repair Time: 20 min

Preparation: Remove the Covers

Important: This procedure can only be performed by authorized service personnel.

Step	Procedure
1	 Caution: Turn OFF the Printer and unplug the power cord from the Printer.
2	Remove the covers to access the mainboard. Remove all the wire connections from the Mainboard.
Step	Procedure

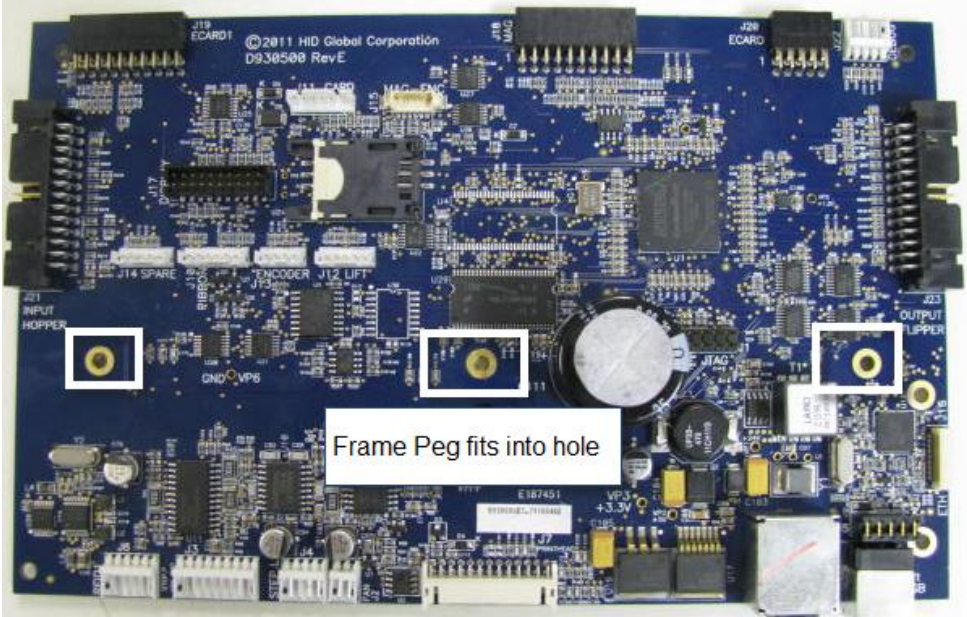
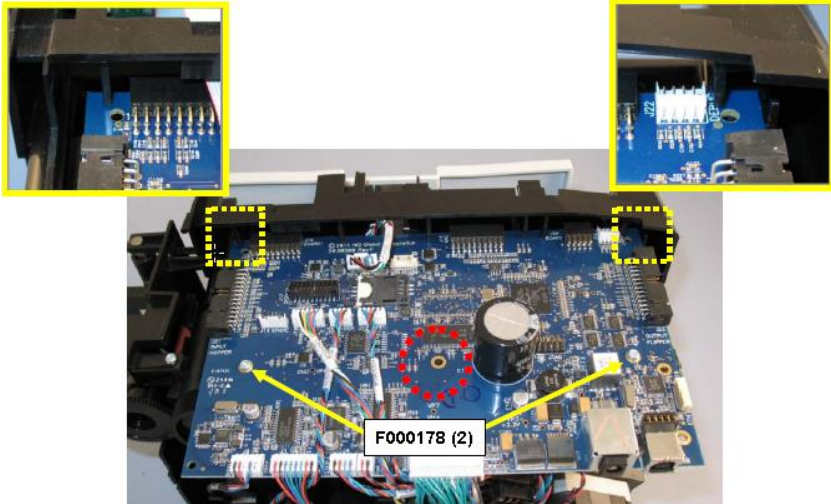
<p>3</p>	<p>Remove the 2 screws (F000178) shown. The center open hole is for the frame peg.</p> 
<p>4</p>	<p>Slide board out from the slots on the front sideplate.</p> 
<p>5</p>	<p>Install new board and reconnect all wires. Wires are labeled for location connection.</p>
<p>6</p>	<p>Procedure is complete.</p>

3.2 Remove/Replace the Stepper Drive Motor (D930027) Remove/Replace Stepper Belt F000424 Remove/Replace Pulley D900430

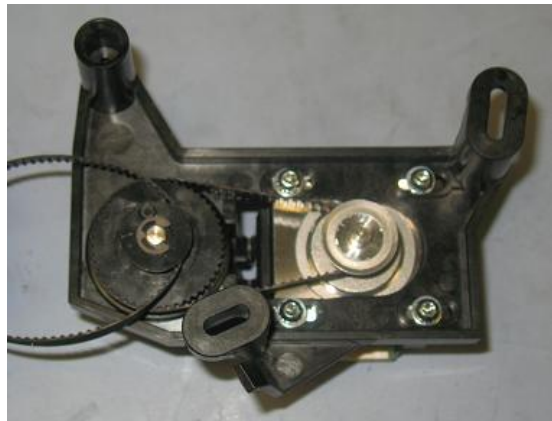

D930028 is Complete Assembly shown

Tools needed: T10 Torx screwdriver

E CLIP tool



Estimated Repair Time: 30 min

Preparation: Remove the Covers

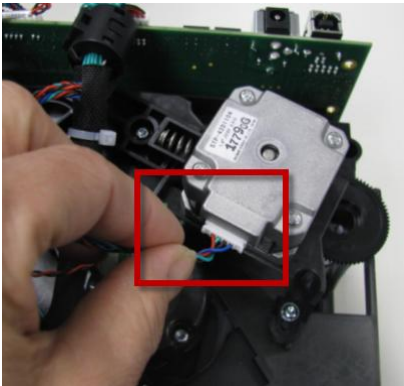
Important: This procedure can only be performed by authorized service personnel.

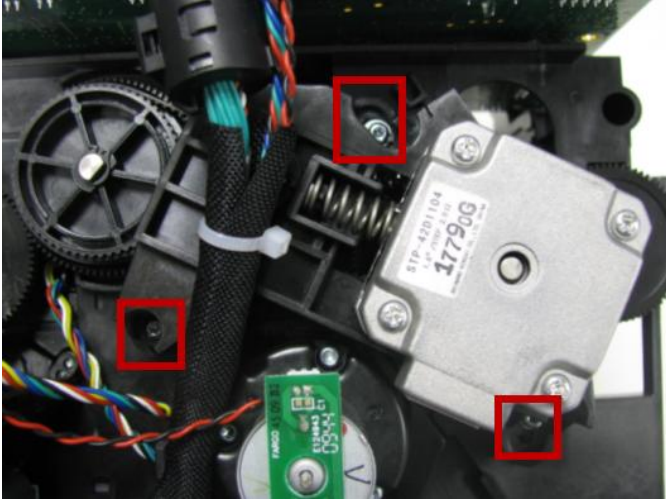
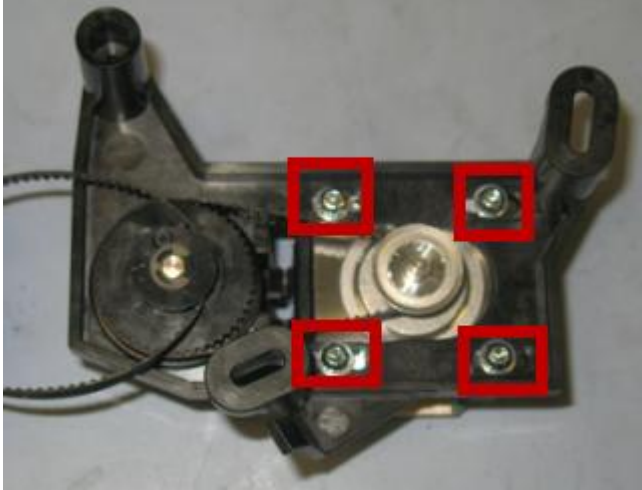
Step	Procedure
1	 Caution: Turn OFF the Printer and unplug the power cord from the Printer.
2	Remove Covers.
3	Lay printer on its front. Remove the cable harness (D930600) from the Stepper Motor. 

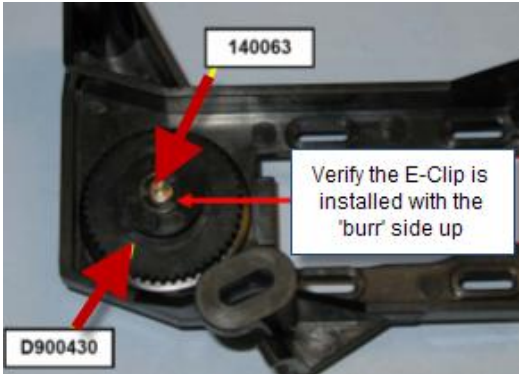
Step	Procedure
4	<p>Remove the 3 screws that hold the Motor/Mount to the printer frame. (Make note of where the 2 screw/washers go and the one machine screw. Remove the printhead cable for more clearance)</p> <p>The motor is attached to a plastic mounting frame.</p> 
5	<p>Remove the 4 screws that hold the stepper motor to the mount frame.</p> <p>One belt (F000424) will come off of the platen roller pulley/gear (D900429- not shown).</p>  <p>(Caution: Spring may pop out. Safety glasses required)</p>

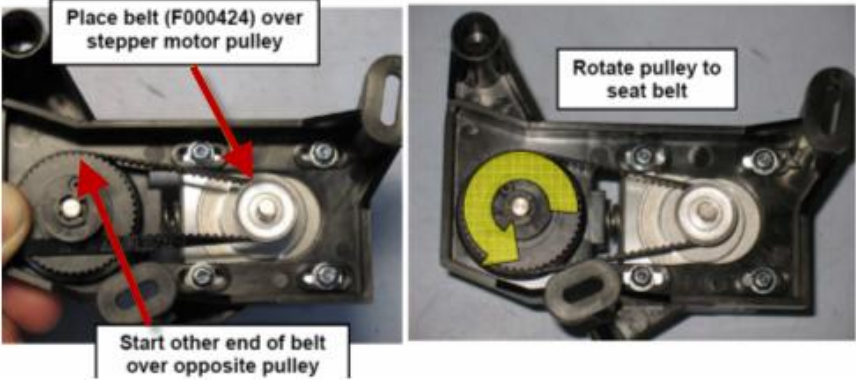

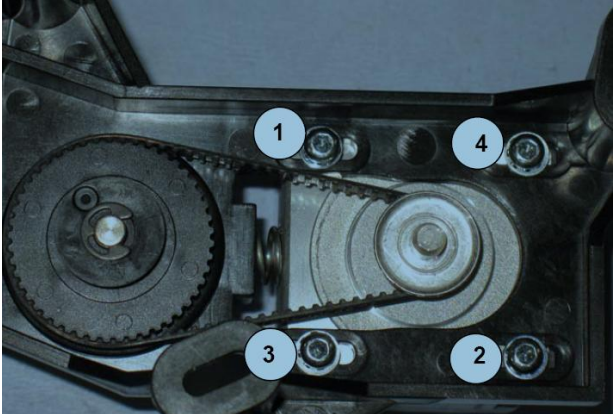
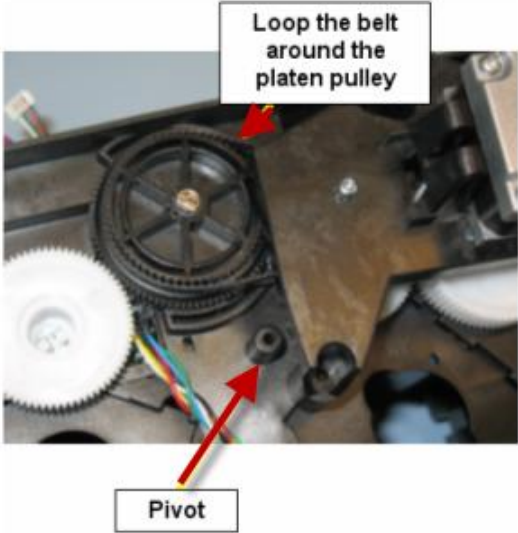
Step	Procedure
6	<p>If replacing the Pulley D900430 remove the E CLIP (140063). Replace with new Pulley. Re- install the E-clip.</p> 
7	<p>Replace the new Motor to the mount frame. Make sure Spring (F000332) gets put back into proper place</p> 
8	<p>Install the belt (F000424)</p> 

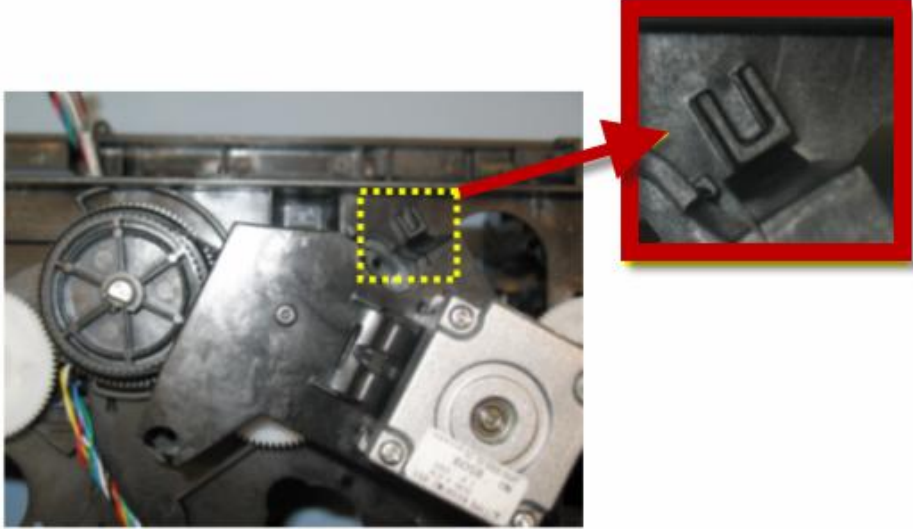
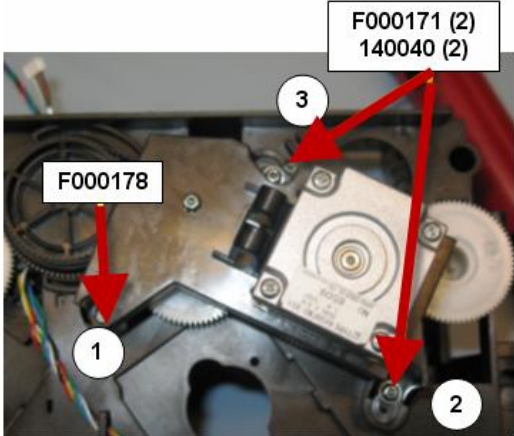
Step	Procedure
9	<p>This Stepper Motor Mount provides a self tensioning feature. Keep the four (4) screws loose while holding the Mount Frame. Allow the spring to self-tension, then tighten the four (4) screws.</p> 
10	<p>Install belt on stepper motor assembly and then loop the belt w/stepper drive assembly around the platen roller shaft gear. Place the Stepper Mount over the pivot peg.</p> 

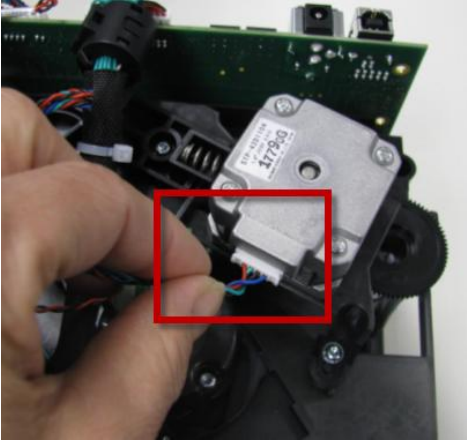
Step	Procedure
11	<p>Fit the Mount behind the tab on the printers side plate frame. This locks the mount in place.</p> 
12	<p>Secure the stepper drive assembly with 2 screws (F000171) with 2 washers (140040), and one screw (F000178) at the specific locations shown.</p> <p>NOTE: Lightly tighten all screws first then tighten the (F000171) screws last.</p> 

Step	Procedure
13	<p>Plug motor cable back in.</p>  <p>Replace the Printhead cable if it was removed in step 4.</p>
14	<p>Procedure is complete.</p>

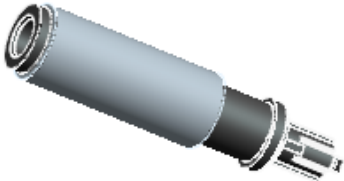
3.3 Remove/Replace the Mag Roller (D930122)

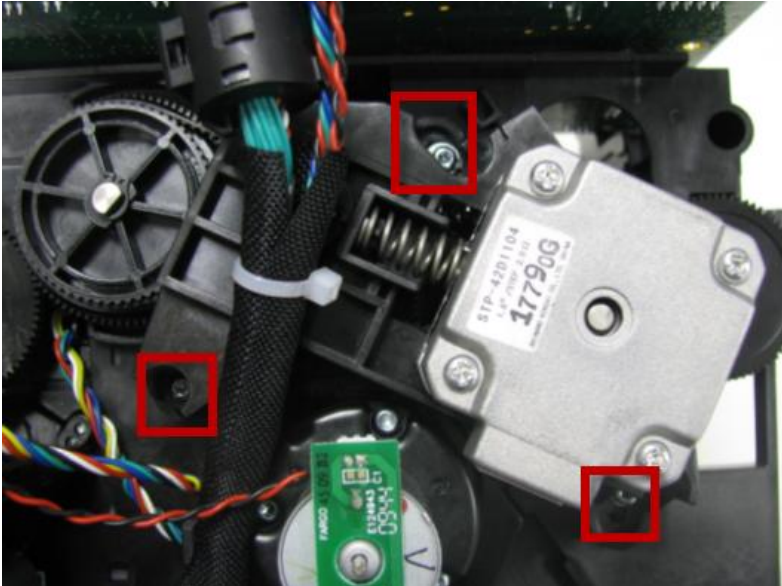
	<p>Located: Rear Sideplate (D930068)</p> <p>Tools needed: Small flat screwdriver, T10 Torx screwdriver</p> <p>Estimated Repair Time: 20 min</p> <p>Preparation: Remove the Covers</p> <p>Important: This procedure can only be performed by authorized service personnel.</p>
Step	Procedure
1	 <p>Caution: Turn OFF the Printer and unplug the power cord from the Printer.</p>
2	<p>Remove the Stepper Motor Assembly (D930028)</p> <p>Remove the 3 screws that hold the Motor/Mount to the printer frame. (Make note of where the 2 screw/washers go and the one machine screw. Remove the Printhead cable for more clearance.)</p> <p>The motor is attached to a plastic mounting frame.</p> 

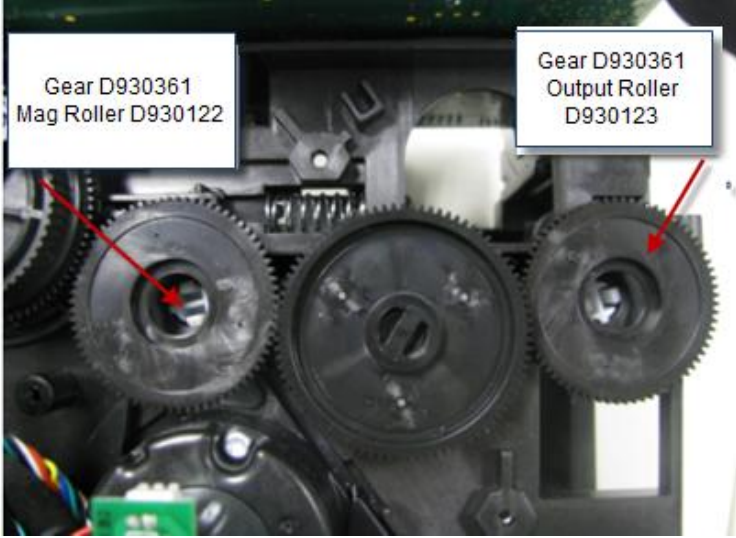
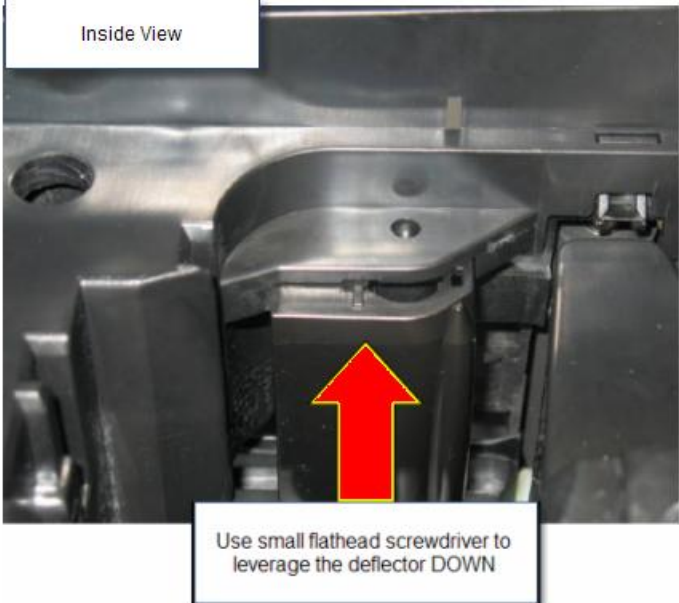
Step	Procedure
3	<p>Remove the Mag Roller Gear (D930361) by pulling out.</p> 
4	<p>Remove the Ribbon Deflector Plate (D930129) to access the Mag Roller. Release the tabs that hold the plate in place.</p> 

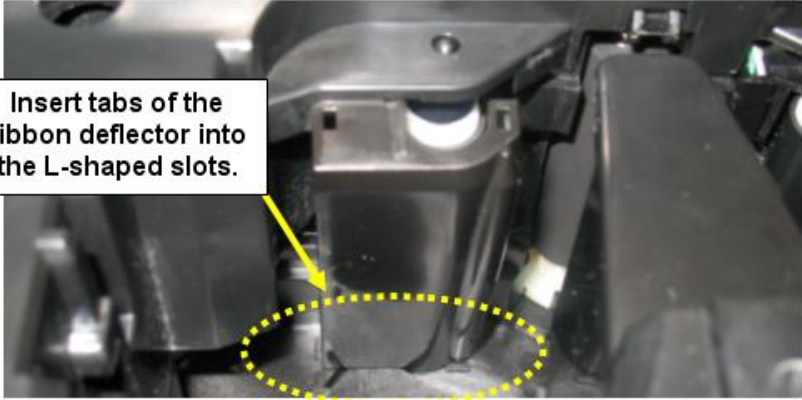
Step	Procedure
5	Pull the Mag Roller out from the front side of the printer.
6	Replace with the new roller. Install the Mag Gear from the back to hold the roller in place. Make sure roller sits in front tab (hidden) in front sideplate. Make sure tabs line up and snap into place. Wiggle in place.
7	Install the Ribbon Deflector Plate. <div data-bbox="345 617 1141 1014" style="text-align: center;">  </div>
8	Re-install stepper motor assembly (refer to Stepper Motor D930028 procedure)
9	Procedure is complete.

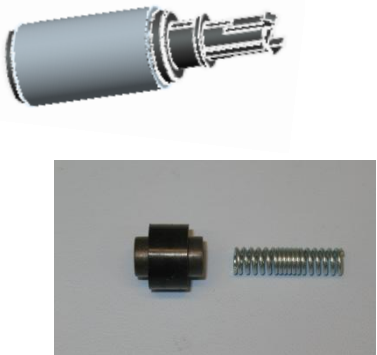

3.4 Remove/Replace the Output Roller (D930123) Remove/Replace Pinch Roller-spring (D920013-F000338)

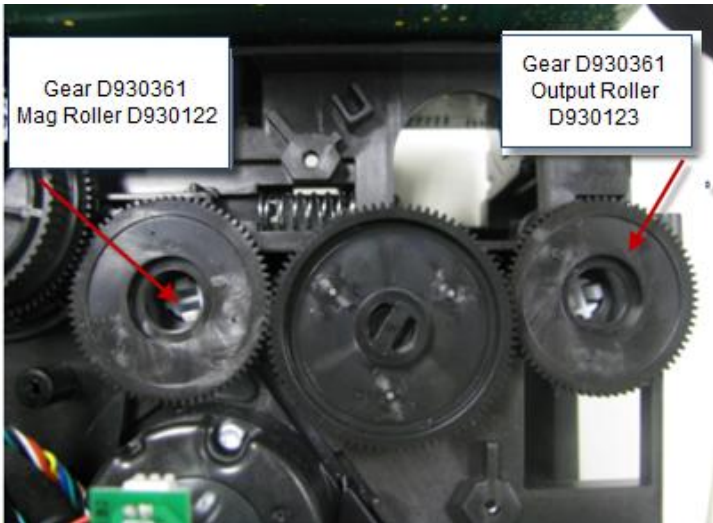

 <p>The image shows the output roller assembly, which consists of a grey cylindrical roller with a metal hub. Below it, the individual components are shown: a metal hub and a small metal spring.</p>	<p>Tools needed: T10 Torx screwdriver</p> <p>Estimated Repair Time: 20 min</p> <p>Preparation: Remove the Covers</p> <p>Important: This procedure can only be performed by authorized service personnel.</p>
---	--

Step	Procedure
1	 <p>Caution: Turn OFF the Printer and unplug the power cord from the Printer.</p>
2	<p>Remove the Output Roller Gear (D930361) by pulling straight out. No need to remove the Stepper Motor Assembly.</p>  <p>The image shows the internal gear assembly of the printer. Two gears are highlighted with red arrows and labels: 'Gear D930361 Mag Roller D930122' on the left and 'Gear D930361 Output Roller D930123' on the right.</p>

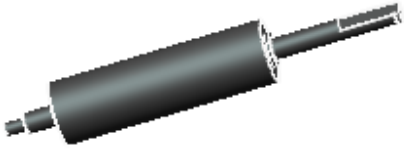
Step	Procedure
3	Flip printer on front remove Roller (D930123) Pull straight up and out
4	Replace with new roller and replace the gear onto the roller. Procedure completed.
5	Remove the output roller first and then remove the Pinch Roller Use a small flathead screwdriver to release the spring (F000338) and the Pinch Roller (D920013). Replace with new roller. <div data-bbox="680 663 969 884" style="text-align: center;"> </div>
6	Reverse assembly to reinstall parts.
7	Procedure is complete.

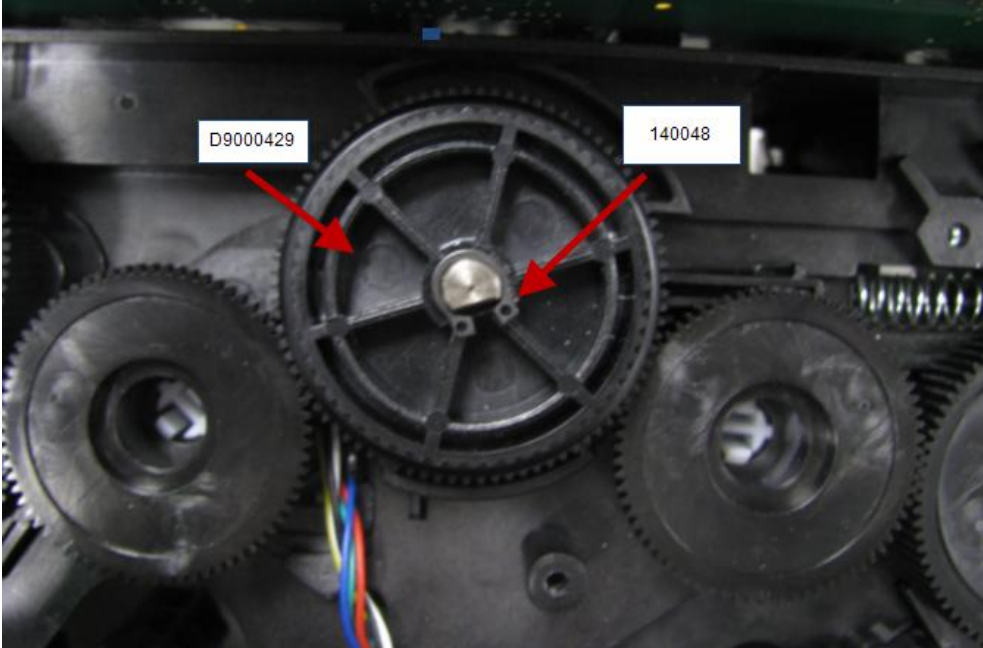
3.5 Remove/Replace the Platen Roller (D930120) & Pulley/Gear (D900429)

	<p>Tools needed: T10 Torx screwdriver</p> <p>Estimated Repair Time: 45 min</p> <p>Preparation: Remove the Covers</p> <p>Important: This procedure can only be performed by authorized service personnel.</p>
Step	Procedure
1	 <p>Caution: Turn OFF the Printer and unplug the power cord from the Printer.</p>
2	Remove the Stepper Motor Assembly (D930028)
3	<p>Remove the E Clip (140048) and the pulley/gear(D900429)</p>  <p>Remove washers from shaft. (Replace the gear if necessary)</p>

Step	Procedure
4	<p>Turn the twist lock Bushing-Twist Lock (D930178) counter clockwise to unlock and lift up. It is not necessary to remove the surrounding gears.</p> 
5	<p>Remove the Platen Cam (D930135). Rotate cam clockwise to remove. Pull off of the Platen Roller Shaft.</p> 

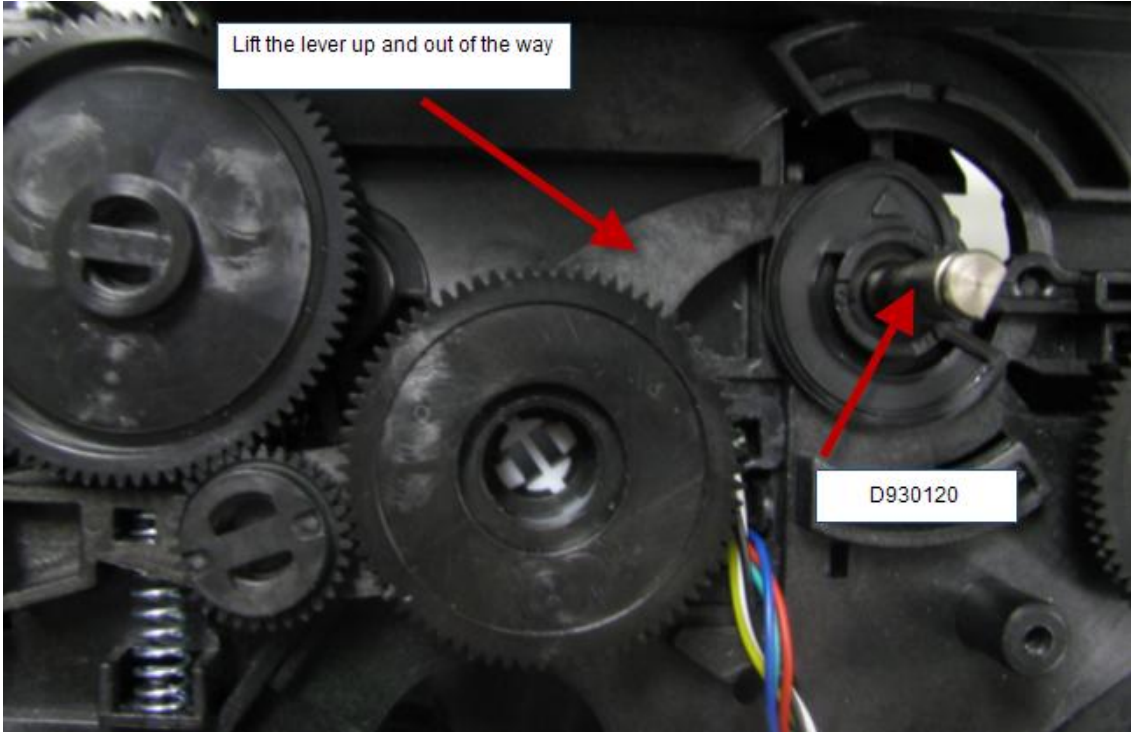
Step	Procedure
6	Remove the print head assembly if better access is needed. See Printhead removal procedure.
7	Move the lever up to clear the Platen Roller (D930120) 
8	Replace with new roller.
9	Reverse assembly to reinstall parts.
10	Procedure is complete.

3.6 Remove/Replace the Lift Pinch Roller Assembly (D930137), Remove/Replace Pinch Lift Bracket (D930136)

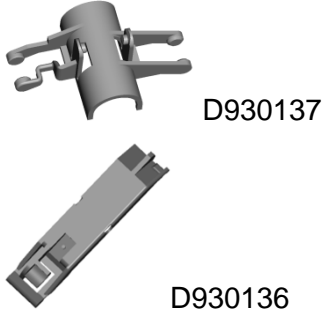
 <p>D930137</p> <p>D930136</p>	<p>Tools needed: T10 Torx screwdriver</p> <p>Estimated Repair Time: 20 Min</p> <p>Preparation: . Remove the Covers</p> <p>Important: This procedure can only be performed by authorized service personnel.</p>
---	--

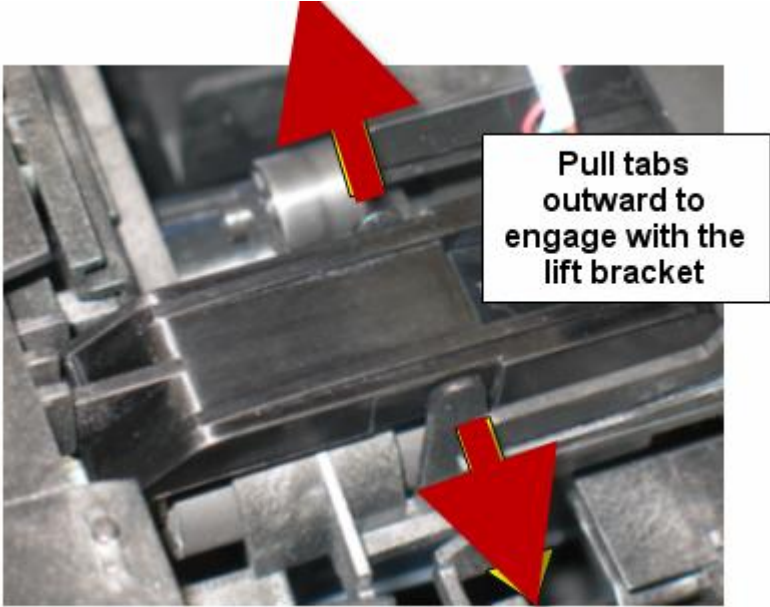
Step	Procedure
1	 <p>Caution: Turn OFF the Printer and unplug the power cord from the Printer.</p>
2	Remove the mainboard .
3	<p>Pull the tabs apart on the Bracket (D930136) to release. Lift up and out.</p> 

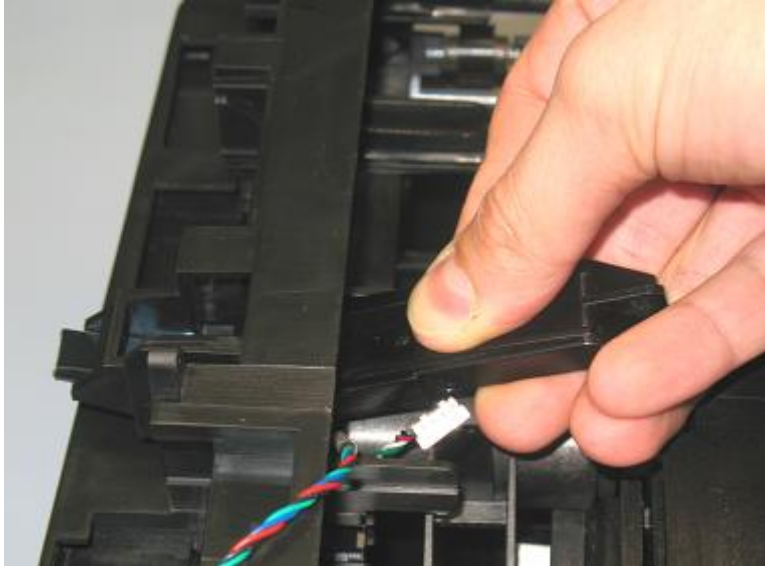
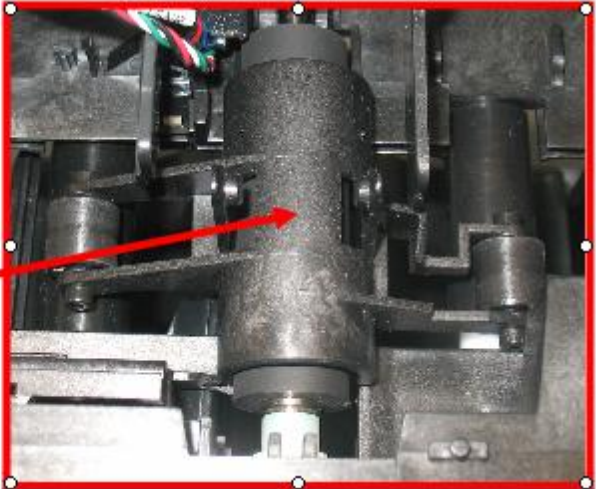
Step	Procedure
4	<p>Rotate the Lift Bracket (D930136) with the spring (D930266) upwards to disengage the hinge.</p> 
5	<p>Lift out the Pinch Roller Bracket (D930137). NOTE: Verify orientation when re installing.</p>  <div data-bbox="342 1297 680 1455" style="border: 1px solid black; padding: 5px; width: fit-content;"> <p>Verify the pinch roller assembly is oriented correctly</p> </div>

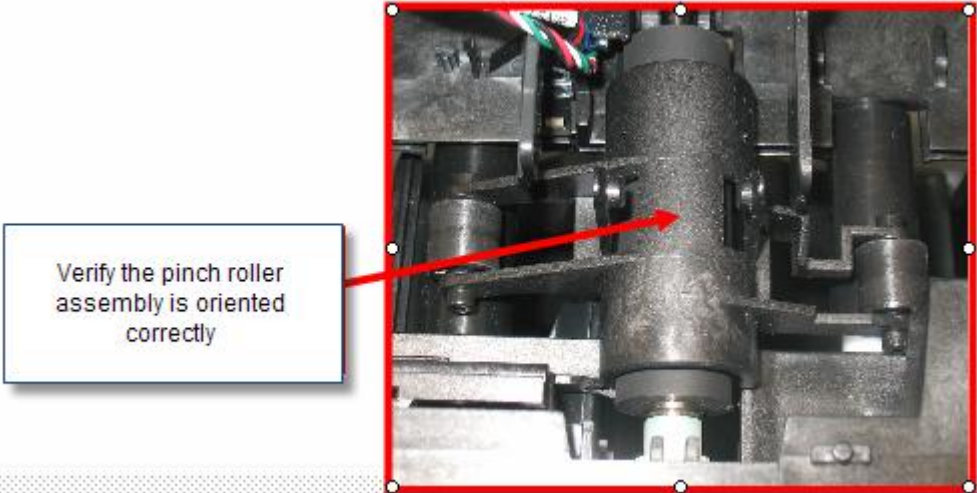
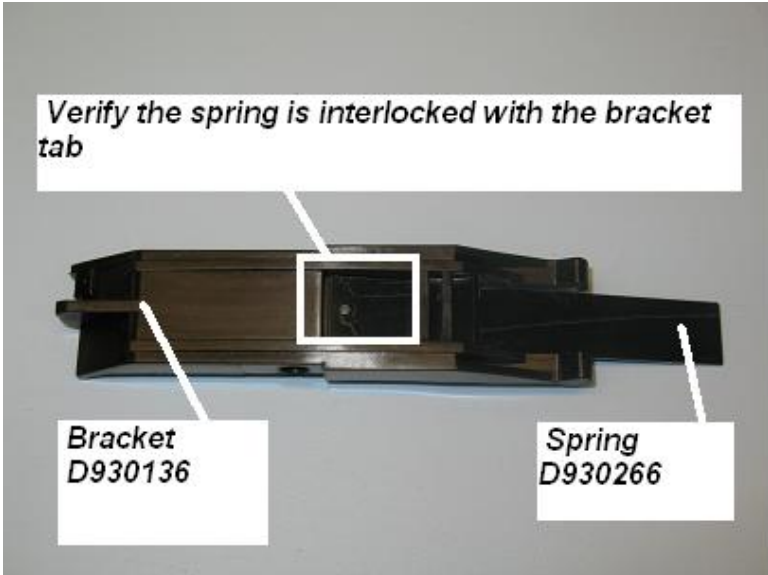
Step	Procedure
6	Replace with new Platen Roller. Lock platen with cam first into the front sideplate.
7	To reinstall the Pinch Roller Assembly: <ol style="list-style-type: none"> <li data-bbox="319 464 964 499">a. Verify orientation of the Pinch Roller Assembly <div data-bbox="342 514 1312 1003" style="border: 1px solid black; padding: 10px;">  <p data-bbox="342 737 683 894">Verify the pinch roller assembly is oriented correctly</p> </div> <ol style="list-style-type: none"> <li data-bbox="319 1024 797 1060">b. Connect the spring to the bracket. <div data-bbox="355 1073 1118 1644" style="border: 1px solid black; padding: 10px;">  <p data-bbox="391 1167 1089 1255">Verify the spring is interlocked with the bracket tab</p> <p data-bbox="410 1488 618 1612">Bracket D930136</p> <p data-bbox="886 1488 1084 1587">Spring D930266</p> </div> <ol style="list-style-type: none"> <li data-bbox="319 1669 1243 1705">c. Insert the Bracket tabs into the holes provided in the sideplate frame.

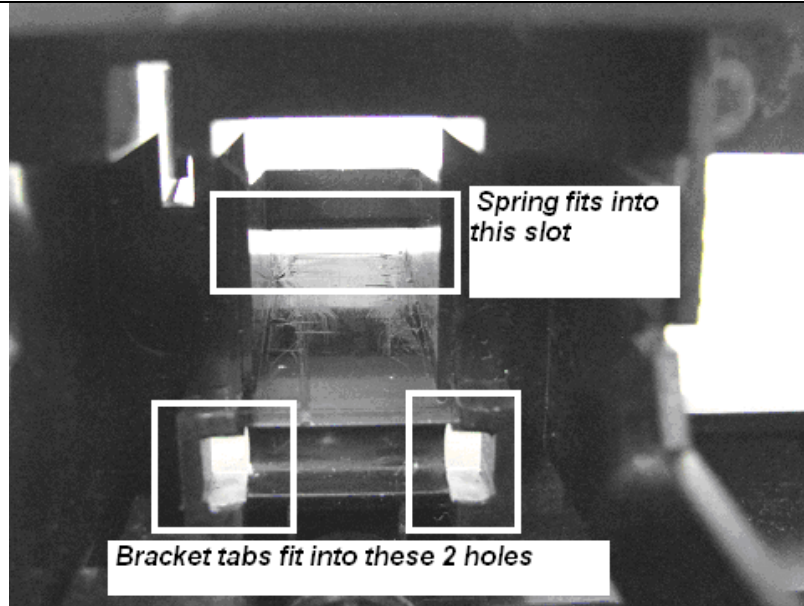

- d. Tilt the spring upward and fit in to the slot provided. Some force is needed to snap the spring and tabs in place.
- e. Click the Bracket into the frame.



f. Snap the Roller Bracket tabs to the Lift Bracket.

Verify both sides of the roller bracket are engaged with the lift bracket

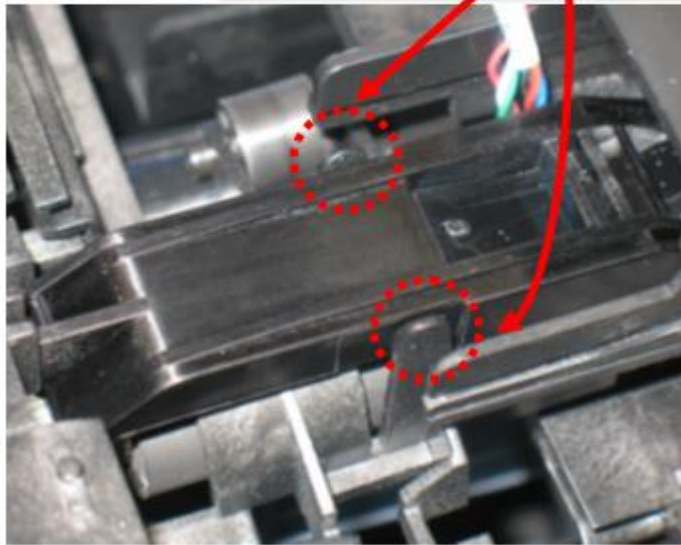

g. Procedure is complete.



3.7 Remove/Replace the Cleaning Roller (D930121), Remove/Replace Input Feed Lever (D930132), Remove/Replace Input Lever Gear (D930164)

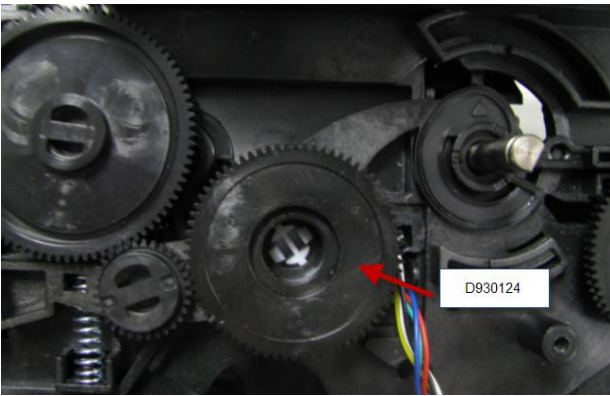

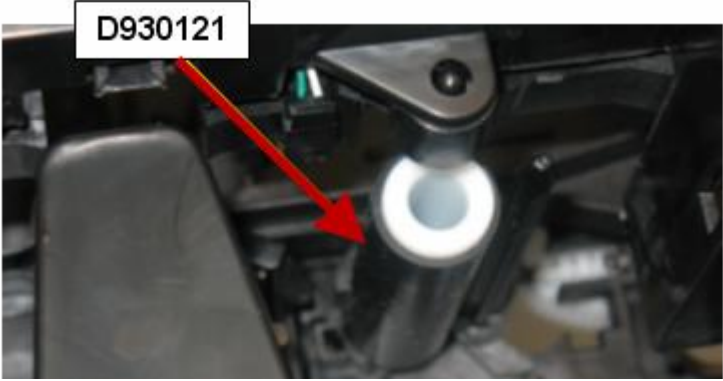
 <p>D930121</p> <p>Gear D930164</p> <p>Lever D930132</p>	<p>Tools needed: T10 Torx screwdriver</p> <p>Estimated Repair Time: 30 min</p> <p>Preparation: Remove the Covers</p> <p>Important: This procedure can only be performed by authorized service personnel.</p>
---	--

Step	Procedure
1	 <p>Caution: Turn OFF the Printer and unplug the power cord from the Printer.</p>
2	Remove the ribbon supply assembly.
3	Remove the mainboard (D930500)
4	<p>Remove the Cleaning Roller Gear (D930124)</p>  <p>D930124</p>

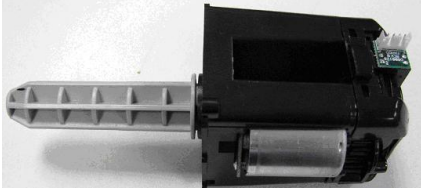

Step	Procedure
5	Remove the stepper motor assembly and belt (D930028)
6	Remove the pulley (e-clip) and washers.
7	Remove platen cam rotation. Locking bushing.
8	Remove the Lever. Be careful not to lose the spring. NOTE: How the spring is set into the pegs. The gear will pull straight out.
9	From the front of the printer release the cleaning roller from the peg by pushing all the way back and dropping the roller. 
10	Replace with new roller.
11	Insert the Spring into the upper and lower pegs. Install the Lever then the Gear. Turn the black platen gear to verify the gears turn simultaneously.
12	Reinstall cam, locking bushing, stepper motor, ribbon supply assembly.
13	Procedure is complete.

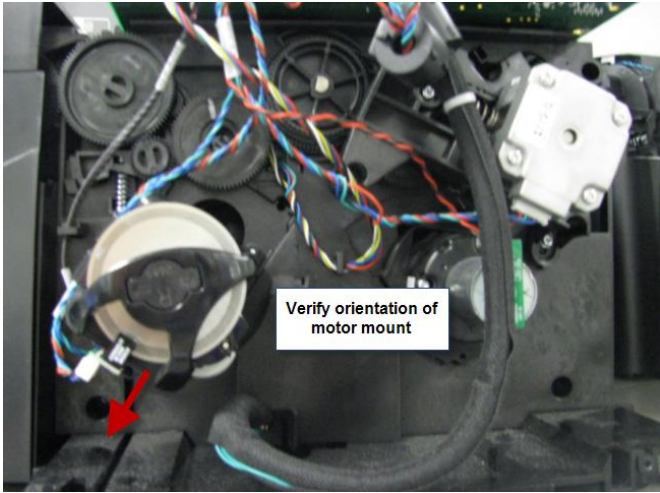
3.8 Remove/Replace Supply Spindle RFID Motor (D930015-01)

	<p>Tools needed: T10 Torx screwdriver</p> <p>Estimated Repair Time: 20 min</p> <p>Preparation: Remove the Covers</p> <p>Important: This procedure can only be performed by authorized service personnel.</p>
Step	Procedure
1	 <p>Caution: Turn OFF the Printer and unplug the power cord from the Printer.</p>
2	<p>Remove the 2 screws (F000178) & washers (140040) from the motor assembly. This is done from the front of the printer.</p> 

Step	Procedure
3	<p>Slide the Supply Spindle DOWN To release. Slide the Motor UP to install.</p> <p>NOTE: You do not need to remove the gears or the Stepper Motor for this procedure.</p>  <p>NOTE: If ribbon wrinkle occurs after replacing the motor, move the motor assembly DOWN slightly in the frame. Loosen the 2- F000178 screws from the supply spindle, move down 1/16th inch then tighten the F000178 screws.</p>
4	<p>Remove the RFID cable (D930603) from the Supply Spindle.</p> <p>Remove the Encoder Sensor cable harness (D930600) from the encoder sensor.</p> <p>NOTE: The routing of these wires under the clip.</p> 
5	<p>Replace the complete assembly Motor.</p> <p>Reconnect wires.</p>
6	<p>Procedure is complete.</p>

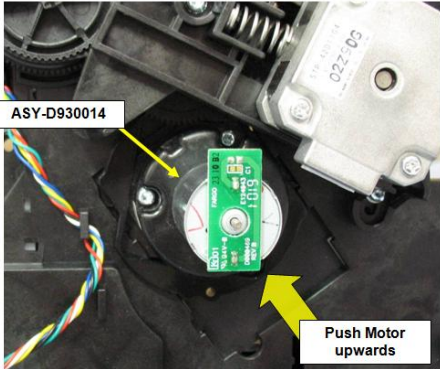
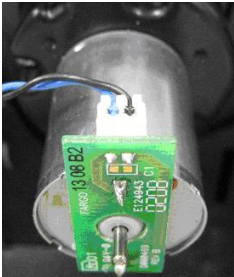

3.9 Remove/Replace Ribbon Take-Up Motor (D930014)

	<p>Tools needed: T10 Torx screwdriver</p> <p>Estimated Repair Time: 20 min</p> <p>Preparation: Remove the Covers</p> <p>Important: This procedure can only be performed by authorized service personnel.</p>
Step	Procedure
1	 <p>Caution: Turn OFF the Printer and unplug the power cord from the Printer.</p>
2	<p>Remove the screw F000178 from the motor assembly. This is done from the front of the printer.</p> 

Step	Procedure
3	<p>From the back of the printer, the motor fits into the track located on the rear sideplate. Slide the Take-Up Motor DOWN to release & remove. Slide the Motor UP to install the replacement.</p> <p>NOTE: You do not need to remove the gears or the Stepper Motor for this procedure.</p>  <p>NOTE: If ribbon wrinkle occurs after replacing the motor, move the motor assembly DOWN slightly in the frame. Loosen the screw (F000178) from the take up spindle, move down 1/16th inch then tighten the F000178 screw.</p>
4	<p>Remove the wire connection (D930600 harness) from the top of the Take-Up Motor.</p> 
5	<p>Replace the complete assembly Motor.</p>
6	<p>Reconnect wires.</p>
7	<p>Procedure is complete.</p>

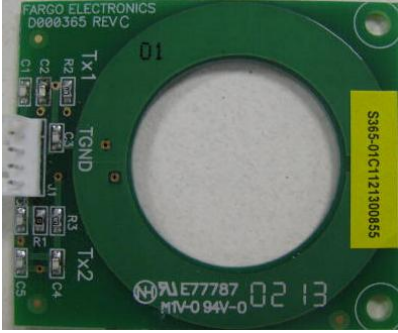

3.10 Remove/Replace Encoder Sensor (A930514) for RFID Supply Spindle/ Cable (D930605), Remove/Replace PCB board (A000365-01)

NOTE: For any other parts (motor/ encoder wheel) REPLACE COMPLETE ASSEMBLY (D930015-01).

 <p>A000365-01</p>  <p>A930514</p> <p>D930605 Cable</p>	<p>Tools needed: Torx screwdriver and flat head screwdriver</p> <p>Estimated Repair Time: 30 min</p> <p>Preparation: Remove the Covers</p> <p>Important: This procedure can only be performed by authorized service personnel.</p> <p>RFID Cable D930603 Encoder Sensor Cable D930605</p>
Step	Procedure
1	 <p>Caution: Turn OFF the Printer and unplug the power cord from the Printer.</p>
2	<p>Remove Supply Spindle-RFID assembly. Refer to:</p> <p>Remove/Replace Supply Spindle RFID Motor (D930015-01)</p>

Step	Procedure
3	<p>Remove the Damper Cap (F000487)</p> <p>Use a thin flathead screwdriver to loosen one side.</p> <p>The cap will pop off.</p> <div data-bbox="509 447 932 886" data-label="Image"> <p>thin screwdriver under tab edge to loosen</p> </div> <p>Note: Replace the Damper Cap by lining up the shaft first then snap the Damper Cap back on.</p> <p>Verify the gray shaft is pushed up to hold the encoder wheel in place.</p> <div data-bbox="537 1094 997 1671" data-label="Image"> <p>Align Shaft as shown</p> </div>

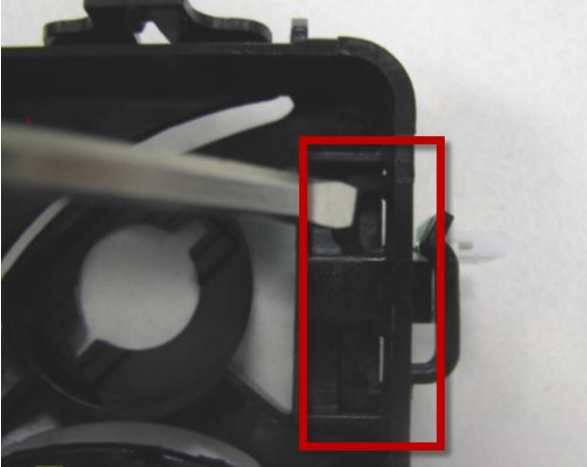
Step	Procedure
4	<p data-bbox="293 296 1198 331">Remove the supply cover (D930116) by pulling up from the open end.</p> <div data-bbox="420 346 1133 871" data-label="Image"> </div> <p data-bbox="293 888 1019 968">This will unlatch the tabs holding the cover to the frame. This allows for access to the sensor.</p> <div data-bbox="420 1035 1175 1612" data-label="Image"> </div>

Step	Procedure
5	<p>Remove the sensor.</p> <p>Use a thin flat blade screwdriver to unlatch the tabs holding the sensor to the frame.</p> 
6	<p>Press the new sensor into the assembly. Make sure the encoder wheel is in between the sensor.</p> 
7	<p>Replace with new Sensor (A930514) and/ or Cable (D930605)</p>
8	<p>Line up the sensor with the slot and snap back in.</p> <p>Reconnect cable to J18</p>
9	<p>Procedure is complete.</p>

3.11 Remove/Replace the PCB board (A000365-01)

Step	Procedure
1	<p>Remove Supply Spindle-RFID assembly. See procedure above (D930015-01). Un-snap the PCB from the frame. The PCB with the HOLES is set under the corner tabs. Lift up this end first. See picture below.</p>
2	<p>Replace with new PCB and/ or Cable.</p>
3	<p>Insert one end first then snap into the corner tabs. Replace cable to J9.</p> <div data-bbox="467 737 834 1129" data-label="Image"> </div>
9	<p>For both procedures route the cables under the holding tab.</p> <div data-bbox="456 1209 906 1530" data-label="Image"> </div>
10	<p>Reverse assembly to reinstall parts</p>
11	<p>Procedure is complete.</p>

3.12 Remove/Replace Ribbon Sensor (D930016)

 <p>ribbon sensor D930016</p> <p>LED Side</p> <p>SENSOR side</p>	<p>Tools needed: T10 Torx screwdriver</p> <p>Estimated Repair Time: 30 min</p> <p>Preparation: Remove the Covers</p> <p>Important: This procedure can only be performed by authorized service personnel.</p> <p>Ribbon Sensor Cable D930608</p>
---	---

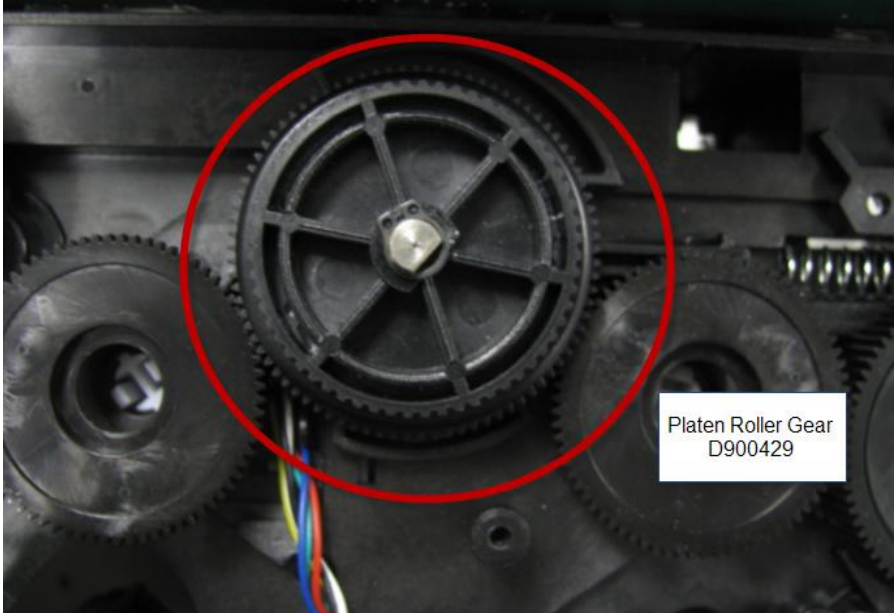
Step	Procedure
1	 <p>Caution: Turn OFF the Printer and unplug the power cord from the Printer.</p>
2	Remove the stepper motor assembly first.
3	<p>Remove the Platen Roller Gears to access the Ribbon Sensor.</p> <p>Remove the retaining ring and pull off the gear.</p>  <p>Platen Roller Gear D900429</p>

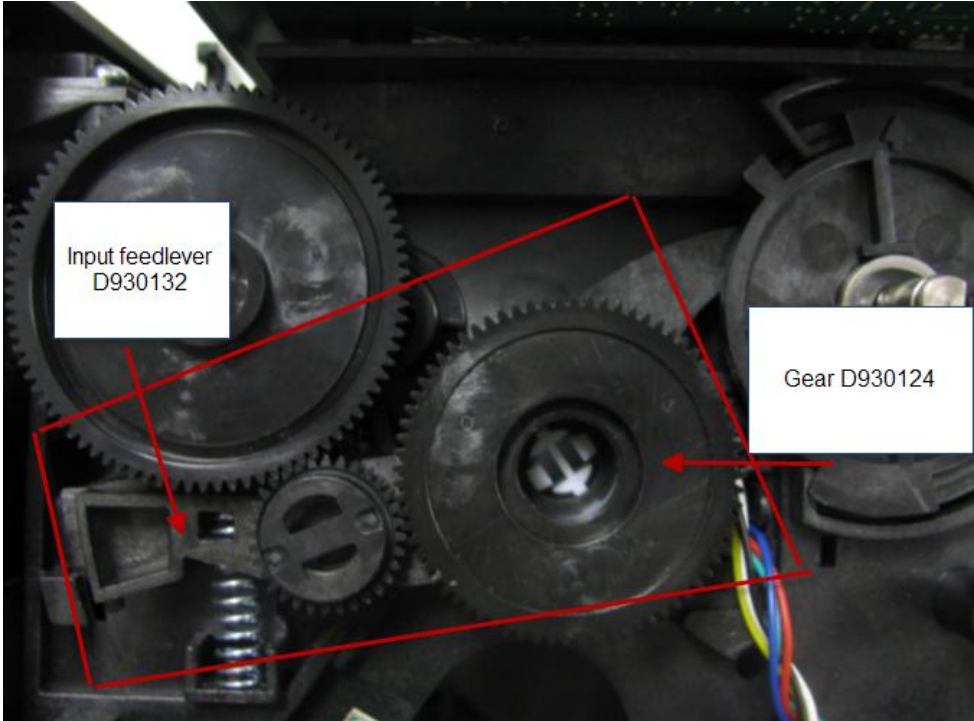
Step	Procedure
4	<p>Remove the Input Feed Lever (D930132), Spring and Gear to access the Ribbon Sensor.</p> 
5	<p>From the INSIDE of the printer: Pinch the tabs on the other side to help remove the sensor from the frame.</p> <p>PUSH the Ribbon Sensor back to release the tabs and remove the sensor.</p>

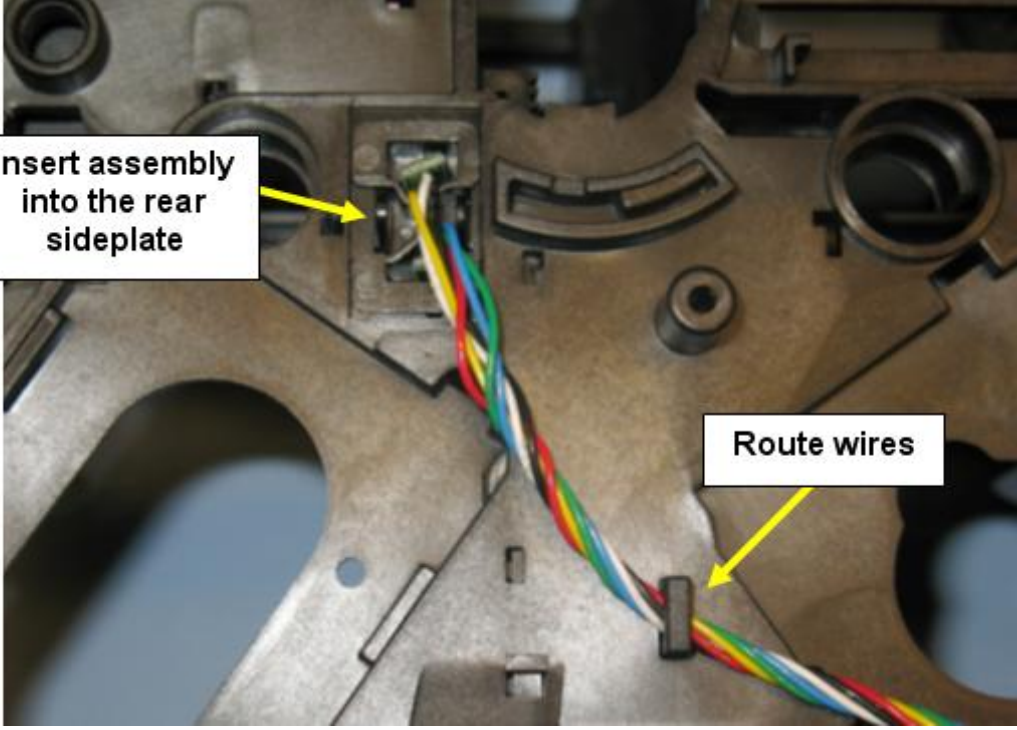
Step	Procedure
6	<p>Replace with the new sensor. Push the sensor back in using the tabs to snap the sensor in place. This is done from the rear sideplate of the printer near the gears.</p> <p>Note: The wire routing to the frame.</p> 
7	Reverse assembly to reinstall parts. Verify wave washer is in place.
8	Procedure is complete

3.13 Remove/Replace Card Path/Cover Sensor (D930613)

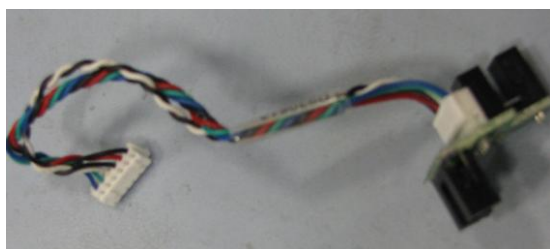

Tools needed: T10 Torx screwdriver
Estimated Repair Time: 30 min
Preparation: Remove the Covers
Important: This procedure can only be performed by authorized service personnel.

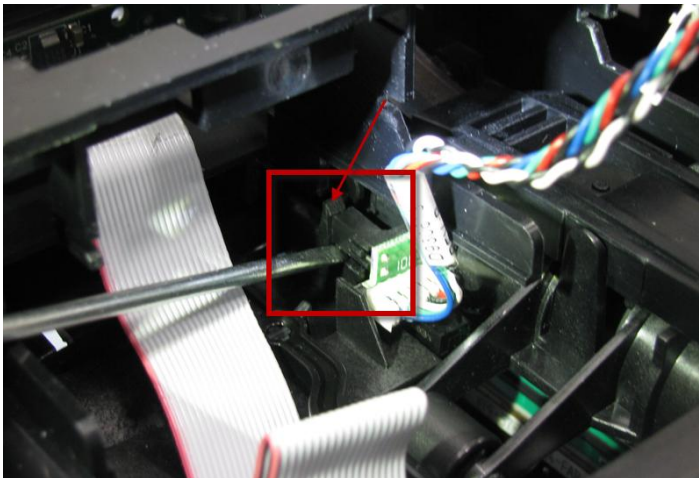
Step	Procedure
1	 <p>Caution: Turn OFF the Printer and unplug the power cord from the Printer.</p>
2	<p>Remove the mainboard. Remove the J11 and J17 connector from the mainboard.</p>
3	<p>Use a small flathead screwdriver to GENTLY pry the sensor up. The sensor must be released from the small tab holding the sensor. (See the RED arrow)</p>  <p>(The cable is shown on THIS side of the frame for clarity.)</p>

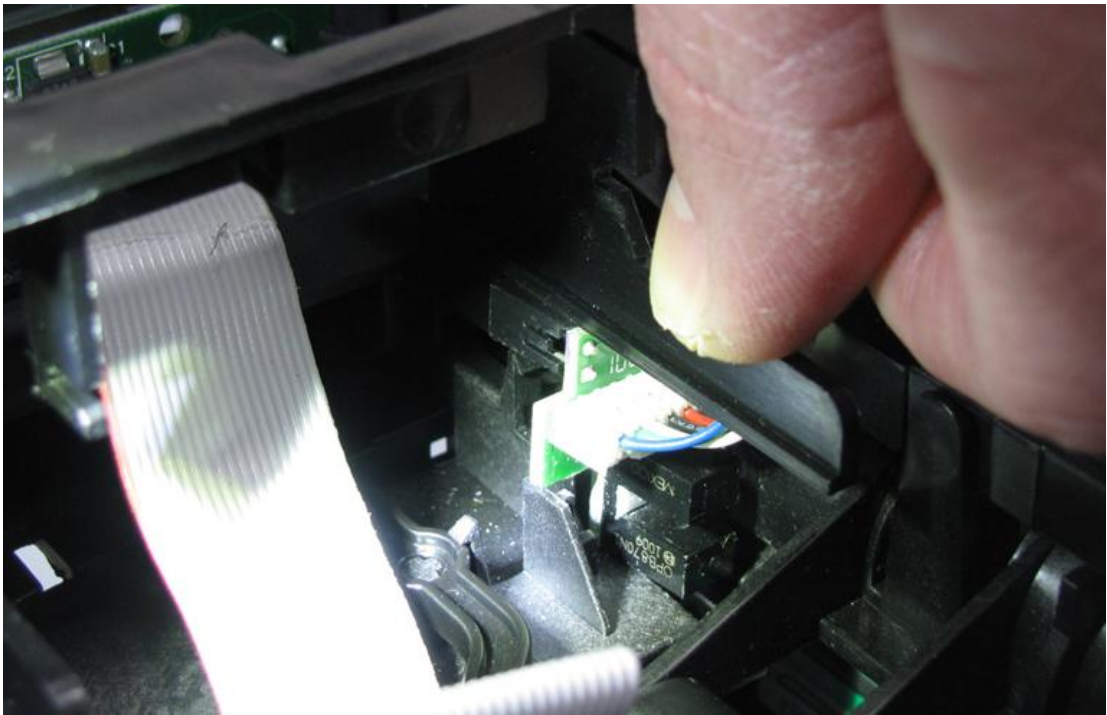
Step	Procedure
4	<p>Replace with the new sensor.</p> <p>Line up the sensor and push down to snap it in place UNDER the small tab.</p> <p>Route the cable on the right side of the frame as shown in the picture below.</p> <p>Connect to the mainboard</p> <p>Reverse assembly to complete the procedure.</p> 

3.14 C50 Printhead procedure

The guide serves to instruct the user about replacing the Printhead. This procedure can only be performed by authorized service personnel.

Kit part number: 047500





Caution: Turn OFF the Printer and unplug the power cord from the Printer.

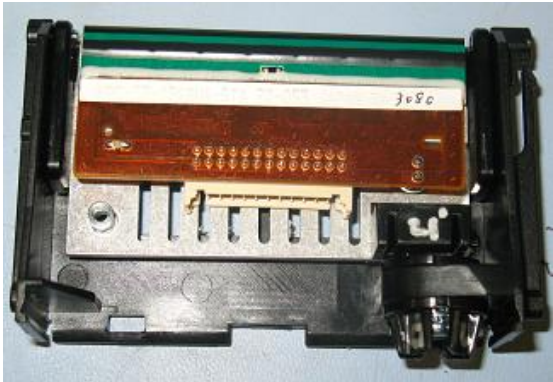

Danger: Wear proper eye protection to perform the procedures in this section.

Reverse the disassembly steps to reassemble the Card Printer. ESD precautions are necessary when handling electronics assemblies.

	<p>Tools needed: Flathead screwdriver Torx Wrench (included in kit)</p> <p>Estimated Repair Time: 20 minutes</p> <p>Preparation: Remove Printhead mount</p> <p>Important: This procedure can only be performed by authorized service personnel.</p> <p><u>Make note of the resistance value on the new printhead; verify this value in the Advanced Settings driver option. Refer to the User Guide for more information.</u></p>
Step	Procedure
1	 <p>Caution: Turn OFF the Printer and unplug the power cord from the Printer.</p>
2	Turn the printer over to access the Headlift cover.

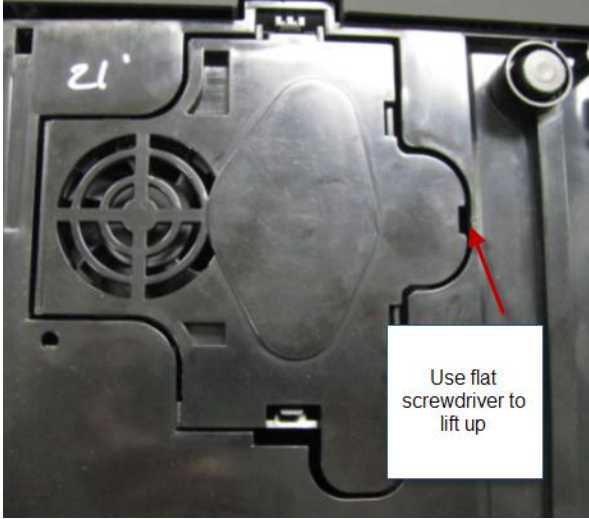
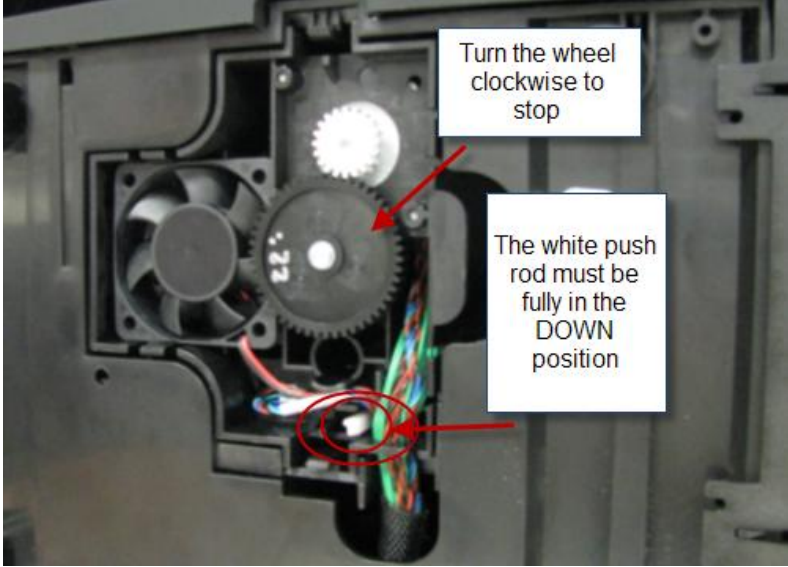

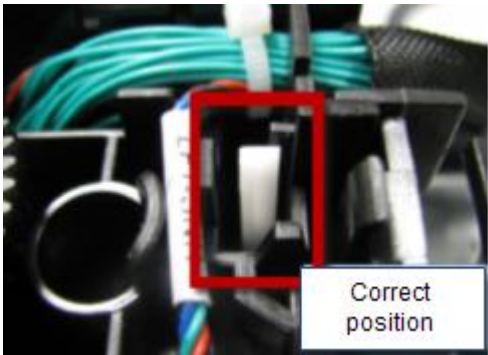
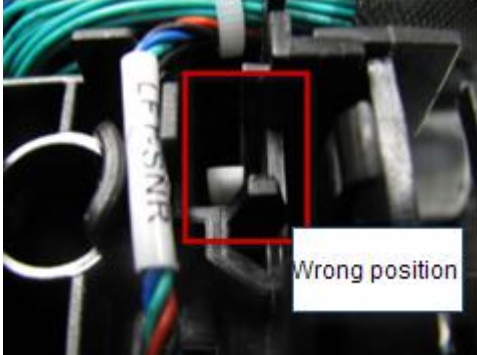
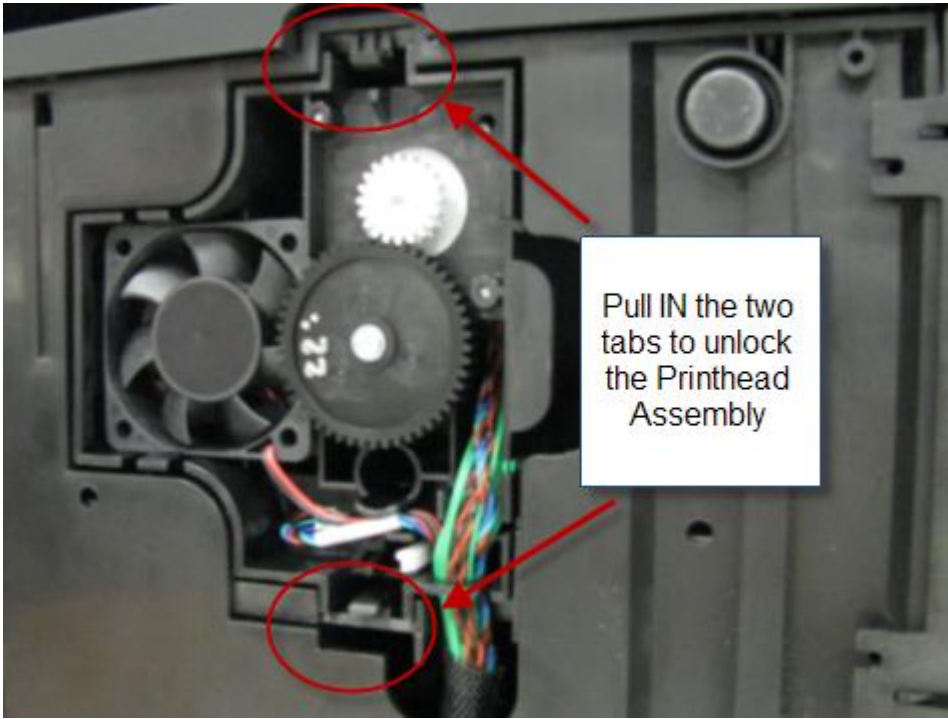
Step	Procedure
3	<p>Use a flathead screwdriver to lift the cover from the frame.</p> 
4	<p><u>VERY IMPORTANT STEP</u></p> <p>Turn the gear clockwise until the Push Rod is in the DOWN position. (in relation to the printer base)</p>  <p>Continued on next page</p>

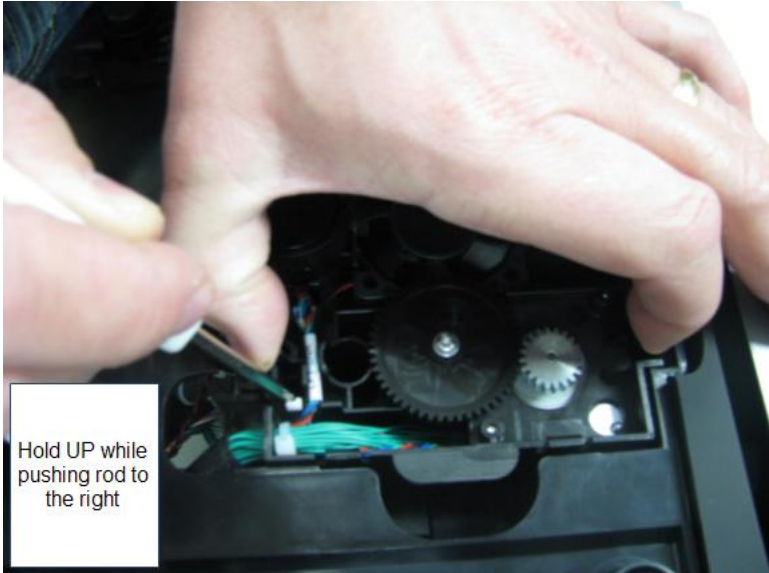
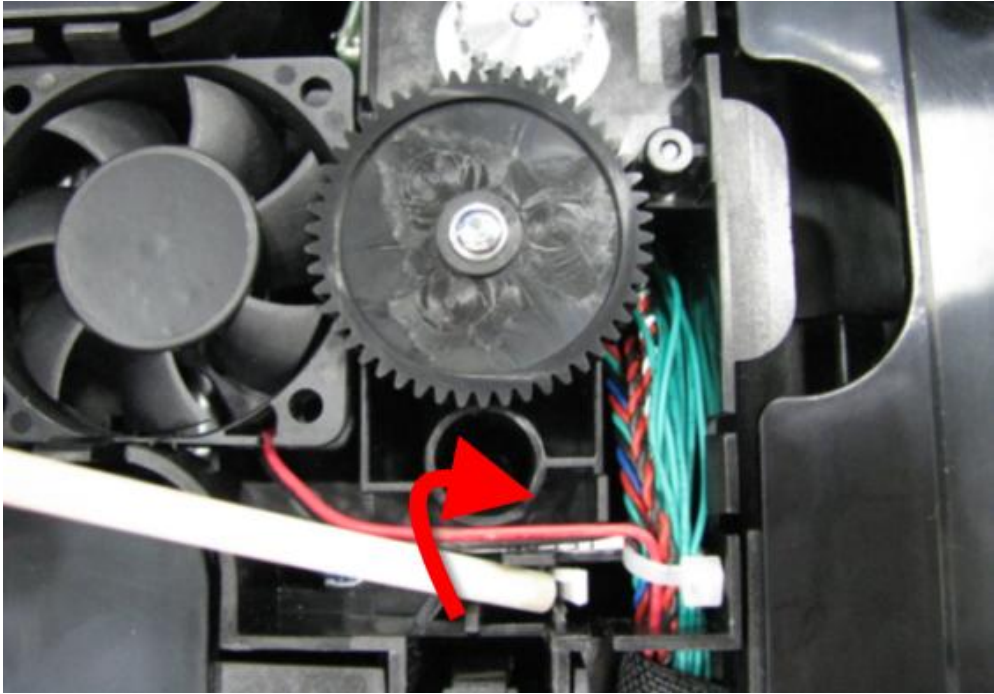
	<div style="display: flex; justify-content: space-around;"> <div style="text-align: center;">  <p>Correct position</p> <p>correct position</p> </div> <div style="text-align: center;">  <p>Wrong position</p> <p>wrong position</p> </div> </div>
<p>5</p>	<p>Pull the 2 tabs IN and pull UP to loosen the Printhead assembly.</p> <p>Hold UP until you can push the white rod to the right.</p> <p>Do not pull up until the push rod has been moved.</p> <p>See step 6 below.</p> <div style="text-align: center;">  <p>Pull IN the two tabs to unlock the Printhead Assembly</p> </div>

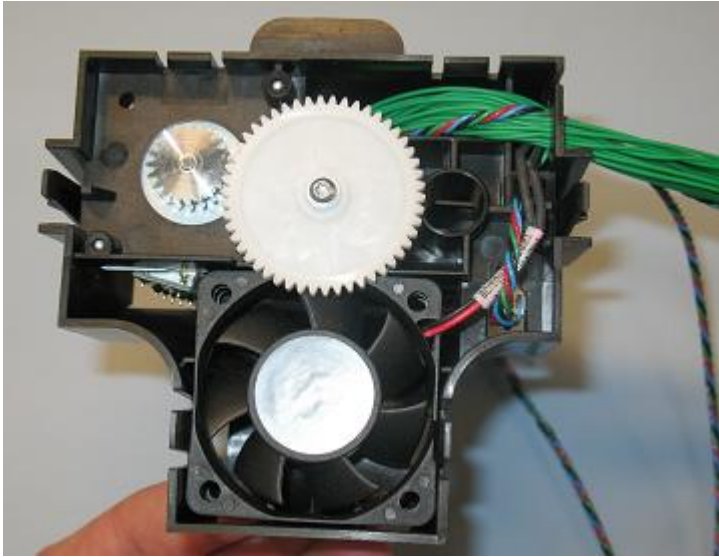

Step	Procedure
6	<p data-bbox="293 296 1230 331">Unlock the push-rod by moving it from the left to the right side of the tab.</p> <div data-bbox="298 346 1062 915">  <p data-bbox="310 730 451 856">Hold UP while pushing rod to the right</p> </div> <div data-bbox="298 982 1286 1671">  </div>

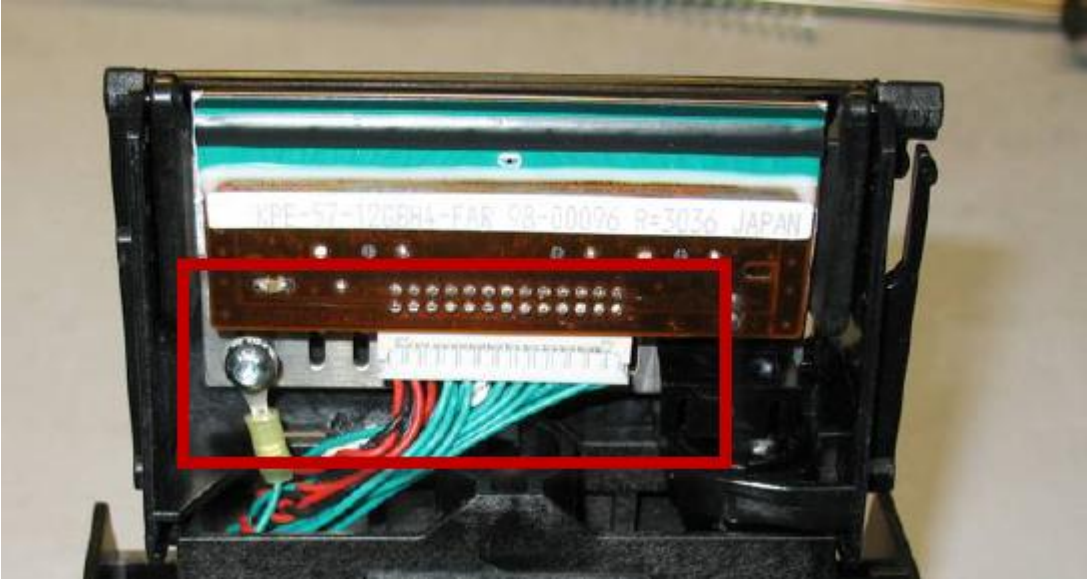
Step	Procedure
7	<p>The printhead assembly can now be pulled up and out from the frame.</p> 
8	<p>The back side of Printhead assembly shown has been removed from the printer.</p> 

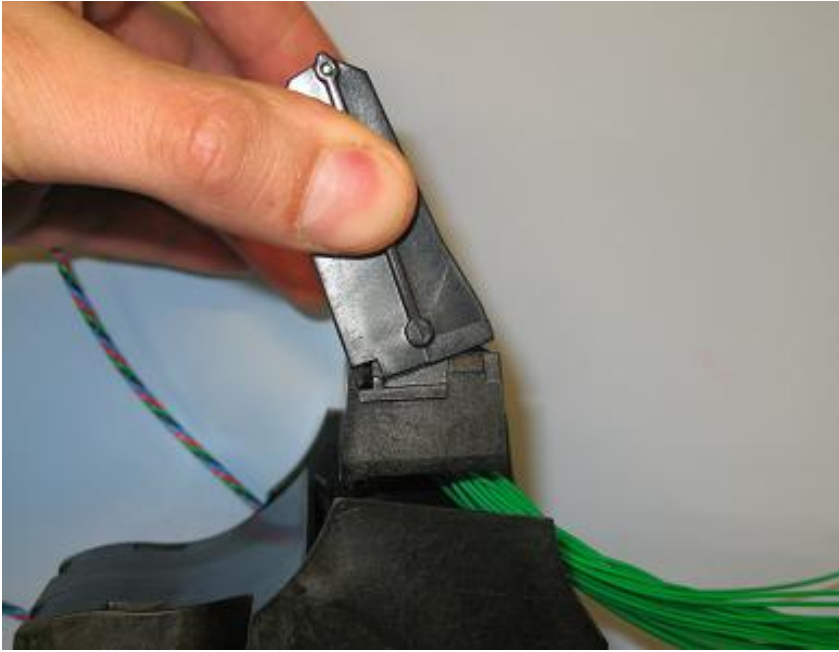
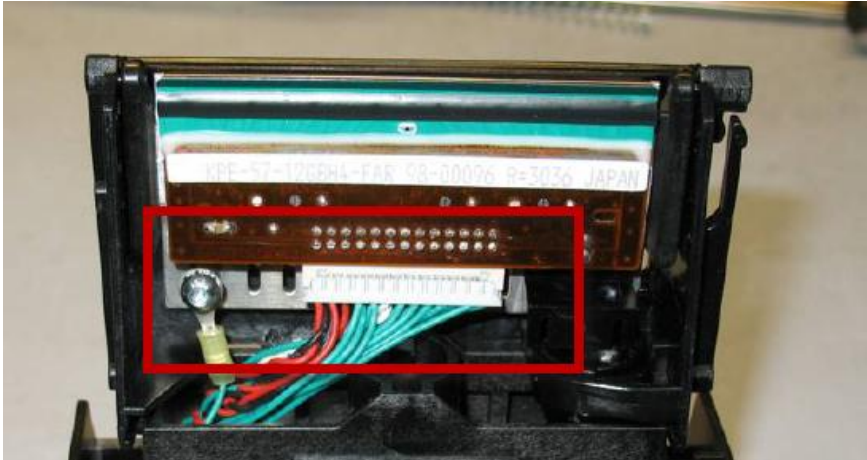

Step	Procedure
9	<p data-bbox="293 296 1425 331">Grasp the printhead mount and rotate to release the printhead from the main assembly.</p> 

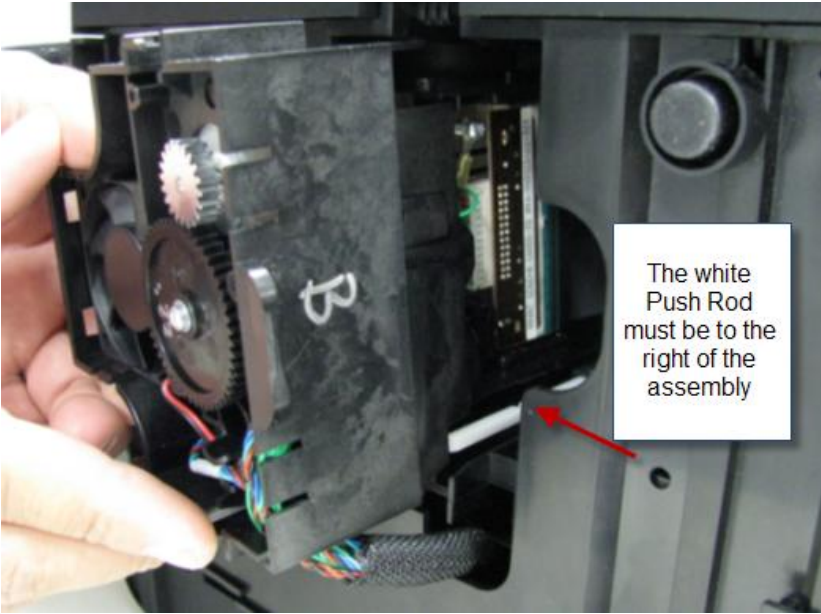
Step	Procedure
10	<p>Remove the cable (D930602). Be careful not to damage the pins. Remove the Torx screw (F000170) and release the ground cable. Leave the wires in the main assembly.</p> 
11	<p>Before installing the new Printhead make note of the R=xxxx value. This number will be used after the Printhead is installed and ready to make the final adjustment. See Advanced Adjustments below.</p> 

Step	Procedure
12	<p>Replace with the new printhead.</p> <p>Install the printhead assembly holes into the tabs and tilt to snap the printhead assembly into place.</p> <p>Verify the printhead is secure in the mount.</p> 
13	<p>Reconnect the cable and ground cable.</p> 

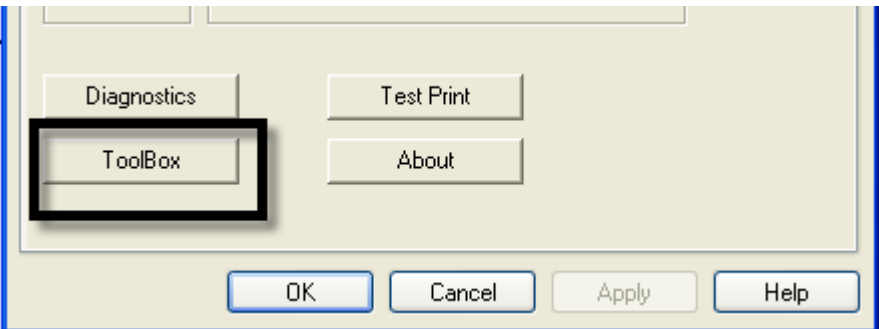
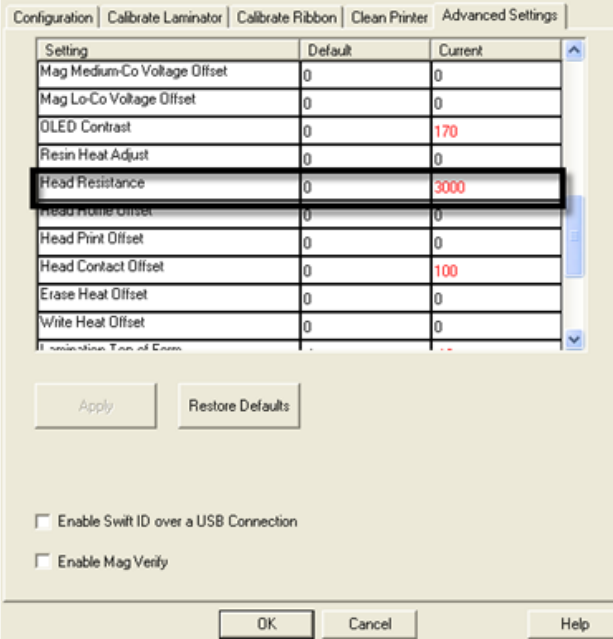
Step	Procedure
14	<p><u>VERY IMPORTANT STEP</u></p> <p>Reinstall the printhead mount assembly into the printer.</p> <p>Line up the Printhead assembly.</p> <p>IMPORTANT NOTE: Verify the white Push Rod is to the right of the assembly before reinserting.</p>  <p>Verify the push-rod is in the correct position. It will rest to the right side of the tab.</p> 
15	<p>CAREFULLY re-insert the completed printhead assembly.</p> <p>Do not scratch the printhead surface.</p>
16	<p>Replace the Headlift cover by snapping back into place.</p>

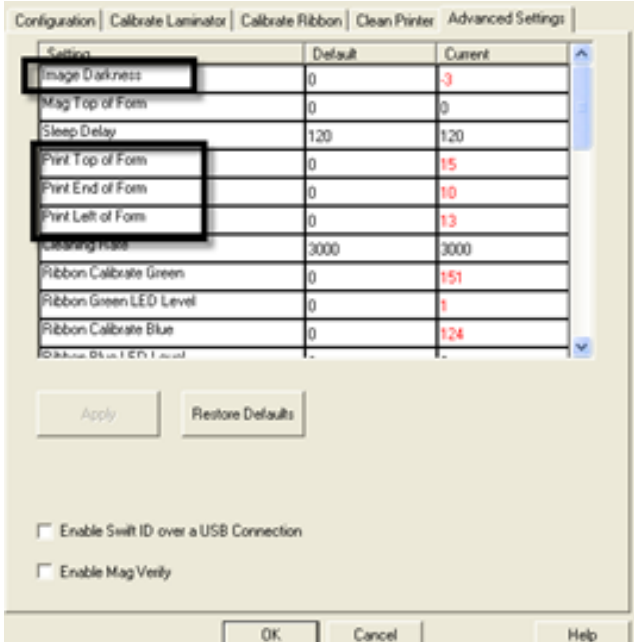
Step	Procedure
17	Procedure is complete after you set the new printhead resistance value.
18	Set the resistance of the new printhead in the Driver Toolbox.
19	Open the Toolbox to access Advanced Settings tab from the printer driver.
20	<p>Open the Toolbox to access Advanced Settings tab from the printer driver.</p> 
21	<p>Use the R=xxxx number from step 11. Add this number to the CURRENT box and click OK to save OR proceed to the TOF, EOF or LOF adjustments below.</p> 

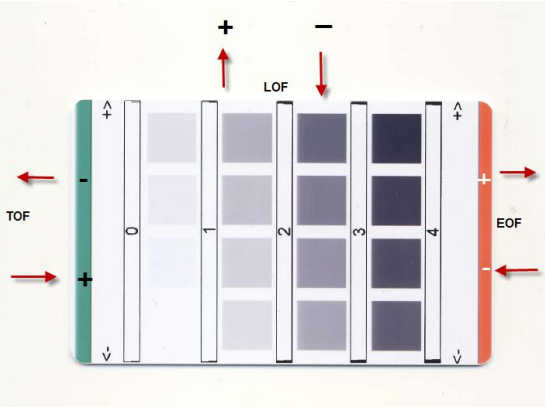
Step	Procedure
22	<p>Adjust the Image Darkness, Print Top of Form (TOF), Print End of Form (EOF), and Print Left of Form (LOF) as needed by increasing or decreasing the CURRENT setting numbers.</p> <p>NOTE: Refer to the Advances Settings section in the User Guide.</p> 
23	<p>Print the ALIGNMENT test card from the Printer display TOOLS  to fine tune the image placement.</p>  <p>Refer to the User Guide for using TOOLS.</p>

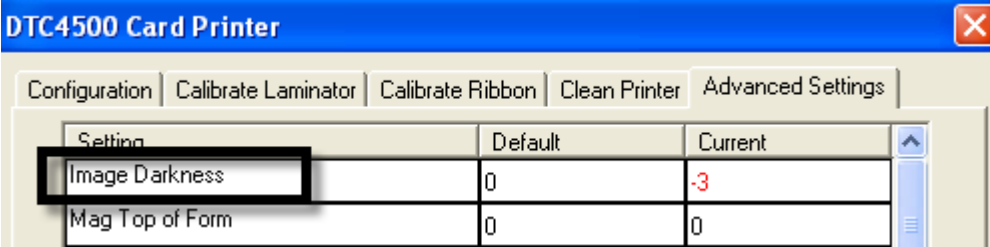
Step	Procedure									
24	<p>To adjust IMAGE DARKNESS: Increase the number to darken the image density or decrease the number to lighten the image density.</p>  <p>The screenshot shows a software window titled "DTC4500 Card Printer" with a close button (X) in the top right. Below the title bar are several tabs: "Configuration", "Calibrate Laminator", "Calibrate Ribbon", "Clean Printer", and "Advanced Settings". The "Advanced Settings" tab is active. It contains a table with the following data:</p> <table border="1" data-bbox="332 499 1185 625"> <thead> <tr> <th>Setting</th> <th>Default</th> <th>Current</th> </tr> </thead> <tbody> <tr> <td>Image Darkness</td> <td>0</td> <td>-3</td> </tr> <tr> <td>Mag Top of Form</td> <td>0</td> <td>0</td> </tr> </tbody> </table>	Setting	Default	Current	Image Darkness	0	-3	Mag Top of Form	0	0
Setting	Default	Current								
Image Darkness	0	-3								
Mag Top of Form	0	0								
25	Procedure is now complete.									

4 Appendix D Printer Mainboard connections

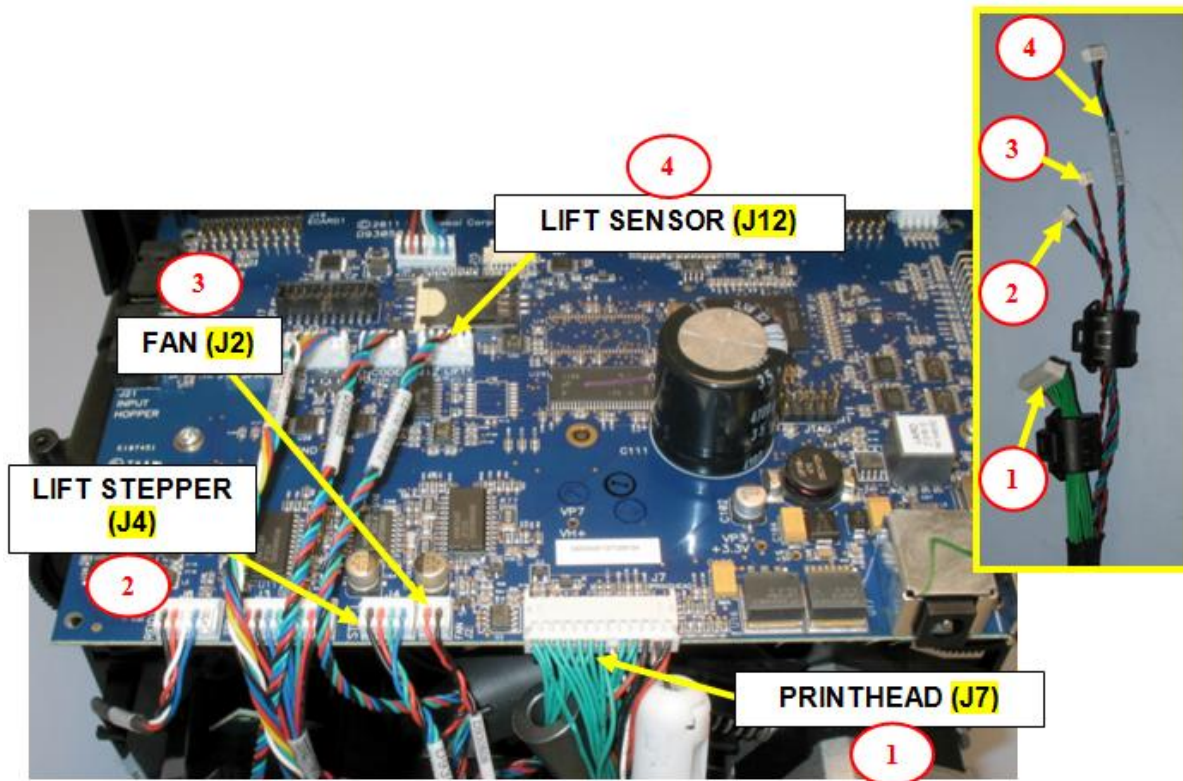

J2-J4-J7-J12 Printhead Harness Cable (D930628) Printhead, Lift Stepper & Sensor, Fan

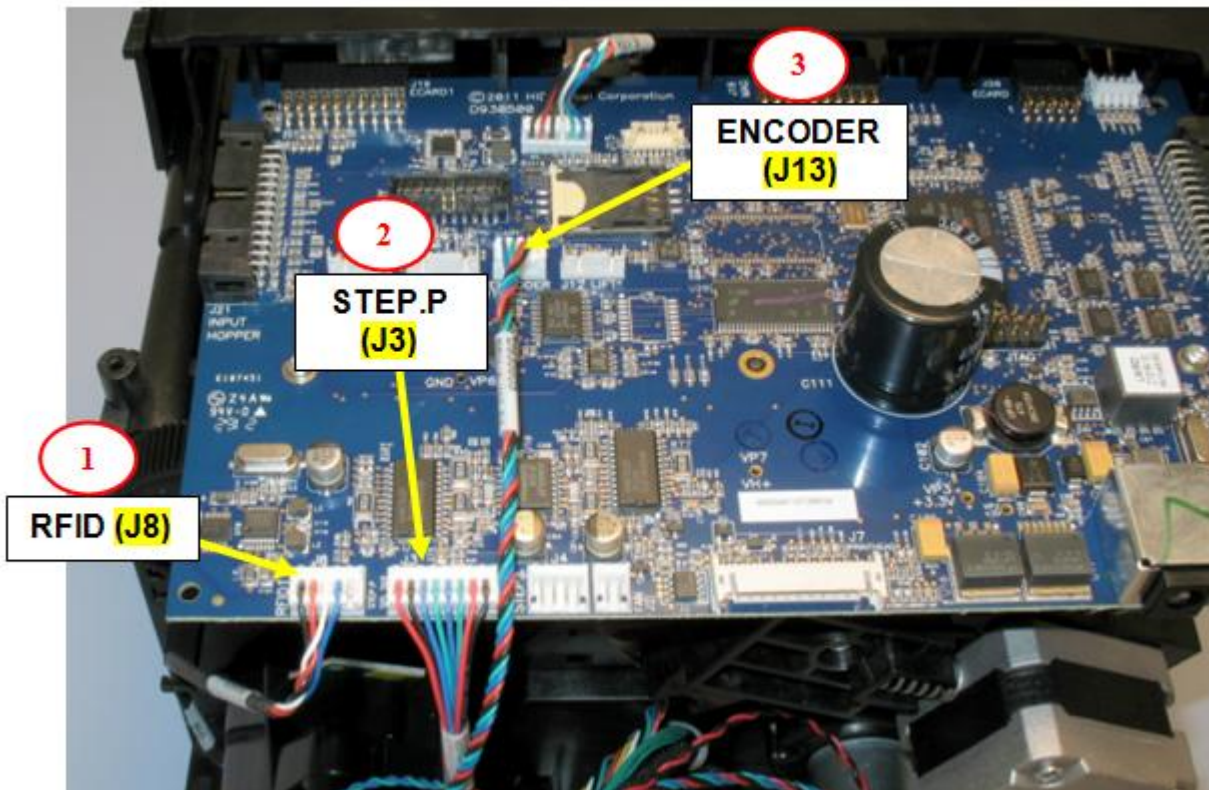

- J3 Motor Harness Cable (D930600) Stepper Motor, Ribbon Supply, Ribbon Take-up
- J8 RFID Cable (D930603)
- J13 Encoder Cable (D930605)

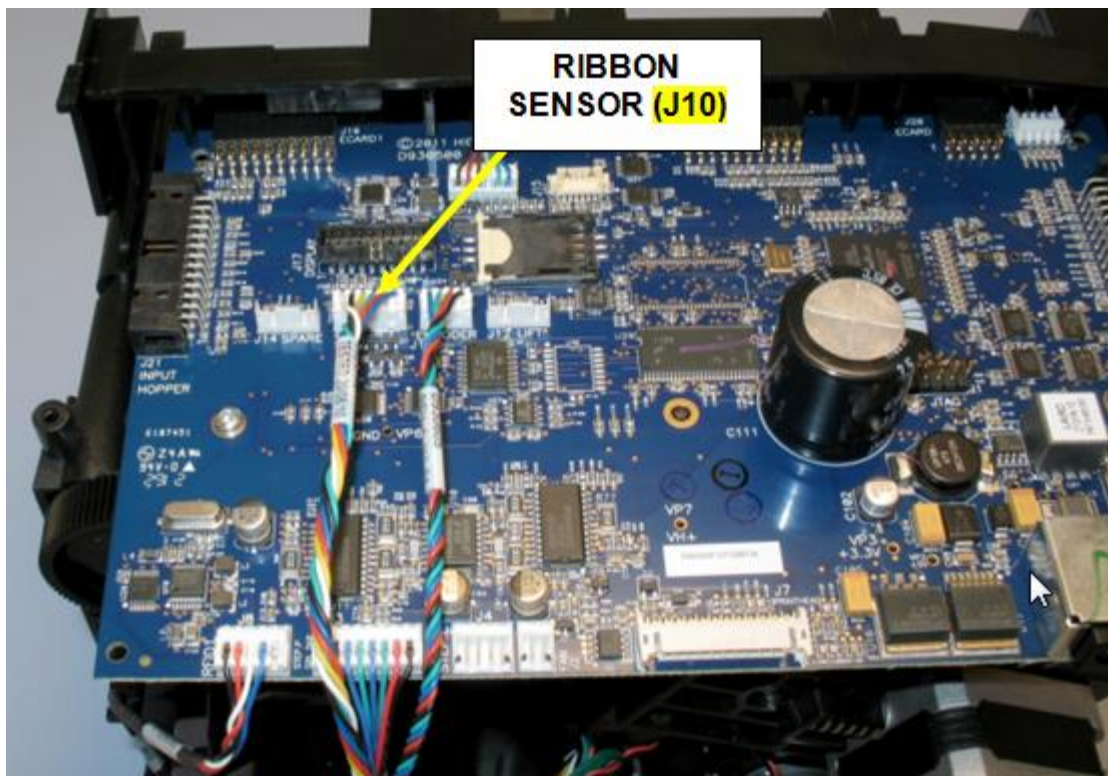

J10 (D930608) Ribbon Sensor Cable

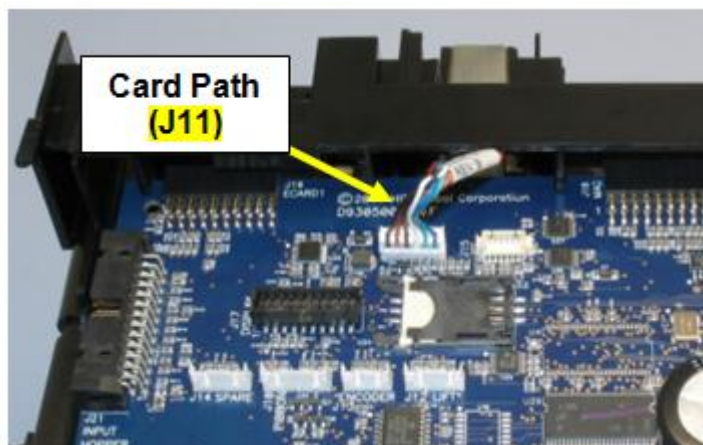

J11 (D930613) Card Path Cable

5 **Appendix E** Engineering Drawings

NOT PRODUCTION VALID W/O STAMP ABOVE

PART NUMBER	D930034-XX	D930263-XX	D930264-XX	D930265-XX
MDP-00278	-03	-04	-04	-03

ITEM	QTY	ITEM NUMBER	TYPE	DESCRIPTION
1	1	D900067-01	PART	DOOR - INPUT
2	1	D930030	ASSEMBLY	ASY-INPUT-MECH-100 CARD
3	1	D930034 -XX	ASSEMBLY	ASY-COVER TOP
4	1	D930262	PART	COVER-FRONT
5	1	D930263 -XX	PART	COVER_LEFT
6	1	D930264 -XX	PART	COVER_RIGHT
7	1	D930265 -XX	PART	COVER-FRONT DOOR
8	1	D930269-01	PART	OUTPUT BIN
9	1	D930370	ASSEMBLY	ASY TAB CARD PATH INSERT
10	5	F000178	PART	SCREW-#4-20X.375_TPH_ZP_PLAS
11	2	F000503	PART	BALL-STEEL
12	2	F000504	PART	SPRING-COMP .420 X .875 X .035
13	1	L001535	PART	LABEL-ENERGY STAR
14	1	MDP-00277	ASSEMBLY	ASY-BASE PRINT ENGINE

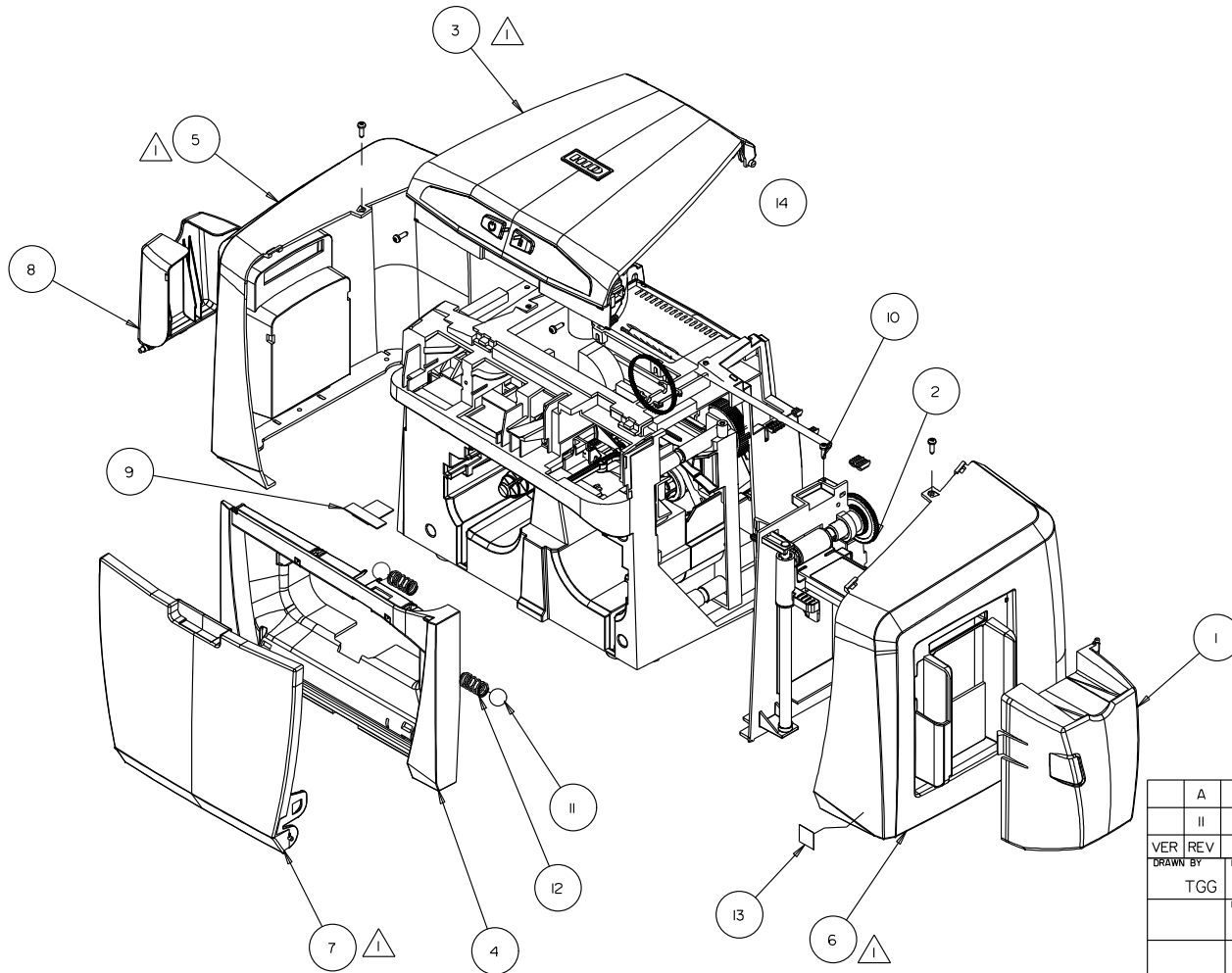

CABLES ARE NOT SHOWN IN DRAWING.

NOTES:

△ THE TABLE IS TO IDENTIFY DASH NUMBERS FOR PART NUMBER COLORS.

	A	NO CHANGES. RELEASED TO REV A.	EMN-00796	21-JUNE-13	TGG/TGG
	II	INITIAL RELEASE	EMN-00714	11-JUNE-13	TGG/TGG
VER	REV	RECORD	ECO#	DATE	DRA/ENG
DRAWN BY	DATE	 <small>HID GLOBAL, CONFIDENTIAL AND PROPRIETARY INFORMATION This document contains confidential and proprietary information, which may not be duplicated, published, disseminated or disclosed to unintended third party recipients (or just "third parties") or used for any purpose, without written permission from HID GLOBAL CORPORATION.</small>			
TGG	18-Mar-13				
	DIM UNITS	inch			
SCALE	SIZE	DESCRIPTION			
0.300	B	ASY-PRINTER C50			
ASSY DWG	PROJECT	ASSY PART NUMBER	ITEM NUMBER		
	ONYX	MDP-00278	MDP-00278		

ENGINEERING USE ONLY		
DRAWING FILE	ENGINEERING MODEL NAME	MODEL TYPE
MDP-00278	MDP-00278	ASSEM

NOT PRODUCTION VALID W/O STAMP ABOVE

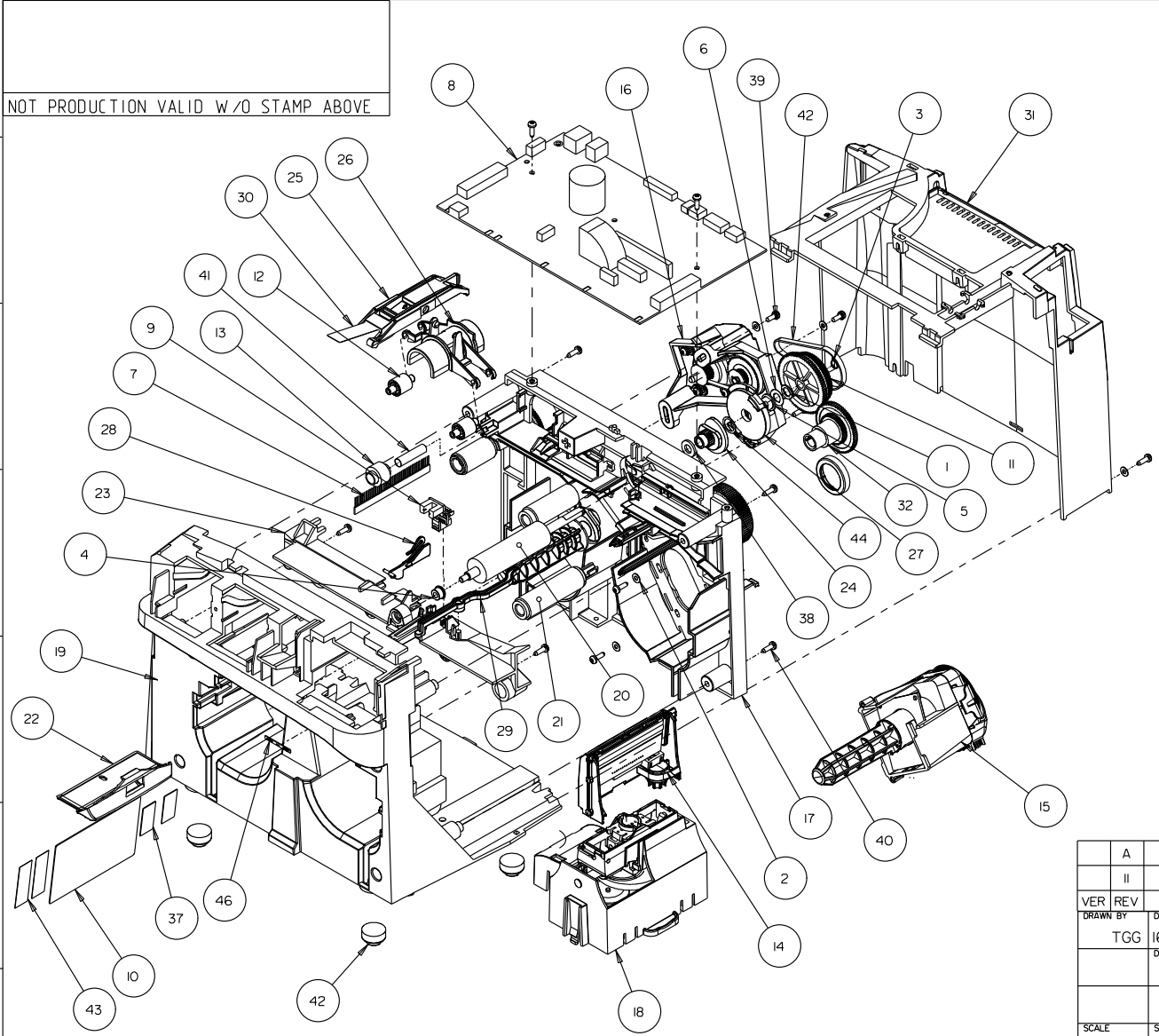

ITEM	QTY	ITEM NUMBER	TYPE	DESCRIPTION
1	1	I30951	PART	WASHER-SPRING.2691D.4230D.006THK
2	7	I40040	PART	WASHER 3MM FLAT
3	1	I40048	PART	RETAINING RING-EXT C .25 IN SHFT
4	1	I760219	PART	BEARING-RIBBON-ROLLER
5	1	I760343	PART	BEARING - DRIVE ROLLER
6	1	I760386	PART	SPACER-CLUTCH
7	1	I810253	PART	BRUSH-STATIC DISSIPATIVE
8	1	I930500-2	PART	ASY-PCB MAIN
9	1	I930513	ASSEMBLY	ASY-CARD COVER SENSOR
10	.002	D000517	PART	CARD PVC NOCO 26.2 MIL BLACK CR80
11	1	D900429	PART	MXL PULLEY- GEAR, COMBO
12	2	D910295	PART	ROLLER-CARD IDLER
13	1	D920013	ASSEMBLY	ROLLER- PINCH
14	1	D930013	ASSEMBLY	ASY PRINTHEAD
15	1	D930015-OI	ASSEMBLY	ASY-SUPPLY-RFID SPINDLE W/SPACER
16	1	D930028	ASSEMBLY	ASY STEPPER DRIVE
17	1	D930068	ASSEMBLY	ASY-REAR SIDEPLATE
18	1	D930083	ASSEMBLY	ASY HEADLIFT
19	1	D930100	PART	SIDEPLATE-FRONT
20	1	D930120	PART	ROLLER PLATEN
21	1	D930121	ASSEMBLY	ROLLER_CLEANING
22	1	D930129	PART	TENSIONER RIBBON
23	1	D930130	PART	CARDPATH-FRONT
24	1	D930135	PART	CAM-PLATEN
25	1	D930136	PART	BRACKET-LIFT PINCH
26	1	D930137	PART	BRACKET-ROLLER PINCH
27	1	D930178	PART	BUSHING-TWISTLOCK
28	1	D930258	PART	FLAG-COVER SENSOR
29	1	D930260	PART	LEVER-CR-79/CR-80
30	1	D930266	PART	SPRING-PINCH ROLLERS
31	1	D930270-OI	PART	COVER-BACK
32	1	D930361	PART	GEAR-DRIVE
33	1	D930600	ASSEMBLY	ASY-CBL MOTORS
34	1	D930603	ASSEMBLY	ASY-CBL-RFID
35	1	D930605	ASSEMBLY	ASY-CBL-ENC-SNR
36	1	D930613	ASSEMBLY	ASY-CBL_CARD/COVER SENSOR
37	2.00	F000145	PART	TAPE_VHB CLEAR X .5 .020" THK
38	1	F000156	PART	SPACER-NYLON .257 X .500 X .062
39	2	F000171	PART	SCREW-M3X8_TPH_ZP_SEM
40	1/4	F000178	PART	SCREW-#4-20X.375_TPH_ZP_PLAS
41	1	F000338	PART	SPRING - COMP .250 X 1.000 X .040
42	1	F000424	PART	BELT. 8I GRV. .080P. .157" W
43	3.00	F000468	PART	TAPE VHB CLEAR X .5 .005"THK
44	1	F000518	PART	WASHER .377 ID .498 OD .005 THK
45	4	F000554	PART	FOOT-RUBBER .67 DIA X .4
46	1	L001609	PART	LABEL CR79-CR80 LEVER

	A	NO CHANGES. RELEASE TO PRODUCTION	EMN-00796	21-JUNE-13	TGG/TGG
	II	INITIAL RELEASE	EMN-00728	05-JUNE-13	DC/TGG
VER	REV	RECORD	ECO#	DATE	DRA/ENG
DRAWN BY	DATE	<p>HID GLOBAL, CONFIDENTIAL AND PROPRIETARY INFORMATION. This document contains confidential and proprietary information, which may not be duplicated, published, disseminated or disclosed to unintended third party recipients (or just "third parties") or used for any purpose, without written permission from HID GLOBAL CORPORATION.</p>			
TGG	16-MAY-13				
	inch				
SCALE	SIZE	DESCRIPTION			
0.340	B	ASY-BASE PRINT ENGINE			
ASSY DWG		PROJECT	ASSY PART NUMBER	ITEM NUMBER	
			MDP-00277	MDP-00277	

ENGINEERING USE ONLY		
DRAWING FILE	ENGINEERING MODEL NAME	MODEL TYPE
MDP-00277	MDP-00277	ASSEM

FARGO

RELEASED

NOT PRODUCTION VALID W/O STAMP ABOVE

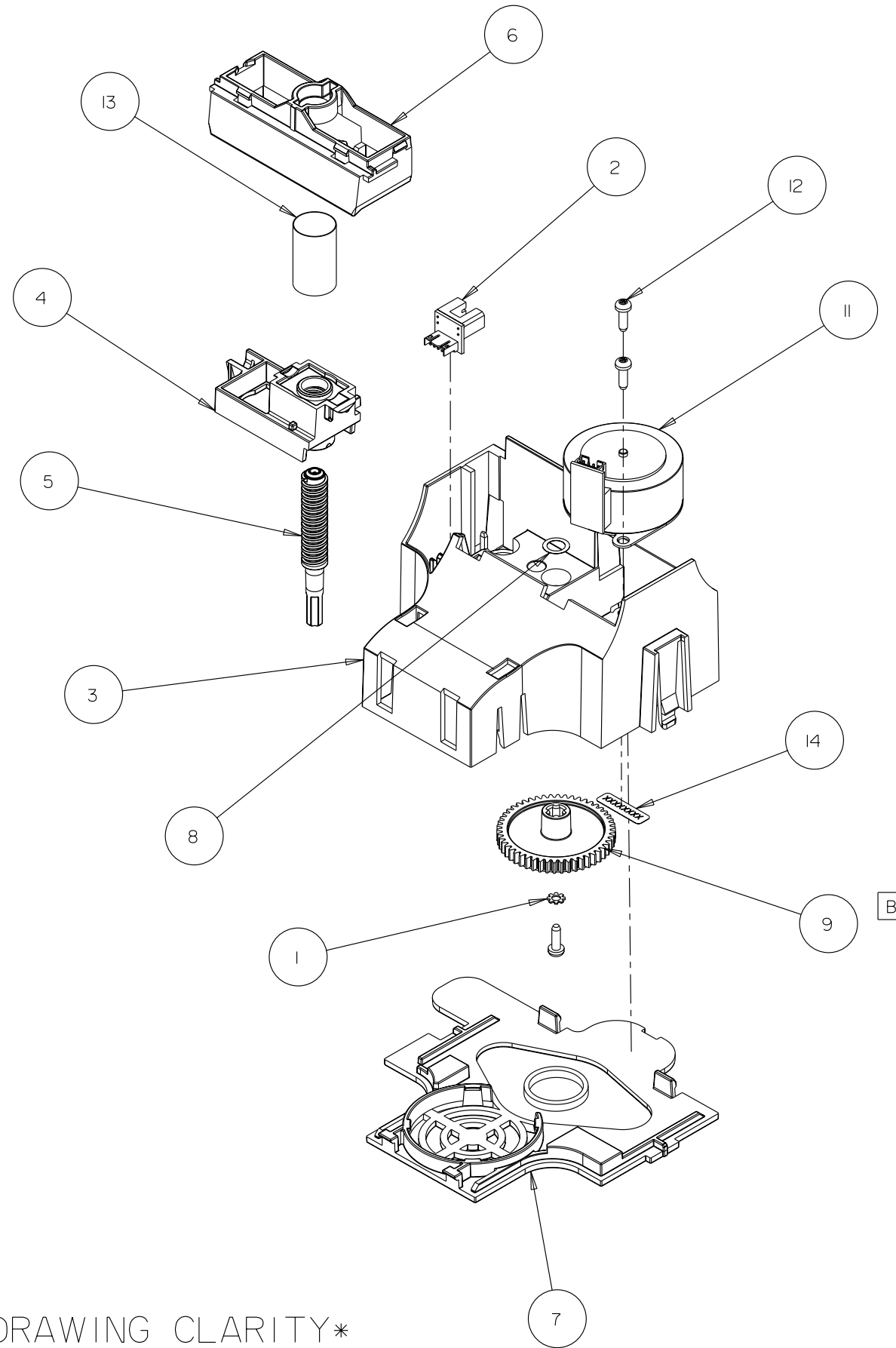

ITEM	QTY	ITEM NUMBER	TYPE	DESCRIPTION
1	1	I40012	PART	WASHER M3 EXT TOOTH LOCKING
2	1	A000462	ASSEMBLY	ASY-PCB SENSOR
3	1	D930102	PART	HOUSING HEADLIFT MAIN
4	1	D930103	PART	BRACKET HEADLIFT THREADED
5	1	D930104	PART	SCREW-LEAD-HEADLIFT
6	1	D930105	PART	BRACKET HEADLIFT SPRUNG
7	1	D930107	PART	COVER HEADLIFT HOUSING
8	1	D930321	PART	WASHER .253ID X .373OD X .005THK
B	1	D930375	PART	GEAR 0.8 MODULE 50 TOOTH
10	1	D930628	ASSEMBLY	ASY-CBL PRINT HEAD HARNESS
11	1	E001192	ASSEMBLY	MOTOR STEPPER 7.5 DEG NMB
12	3	F000178	PART	SCREW-#4-20X.375_TPH_ZP_PLAS
13	1	F000488	PART	SPRING - COMP .600 X 1.00 X .049
14	1	L000790	ASSEMBLY	LABEL - SERIAL NUMBER

	B	UPDATED D930104 TO REV B, REPLACED D930106 WITH D930375	C18720	13-OCT-11	DBC/JS
	A	INITIAL RELEASE	C19002	12-Sep-11	CAR/RF
VER	REV	RECORD	ECO#	DATE	DRA/ENG

DRAWN BY	DATE	<p>HID GLOBAL CONFIDENTIAL AND PROPRIETARY INFORMATION This document contains confidential and proprietary information, which may not be duplicated, published, disseminated or disclosed to unintended third party recipients (or just "third parties") or used for any purpose, without written permission from HID GLOBAL CORPORATION.</p>
CAR	12-Sep-11	
	DIM UNITS	
	inch	
SCALE	SIZE	DESCRIPTION
0.500	B	ASY HEADLIFT
ASSY DWG	PROJECT	ASSY PART NUMBER
		D930083
		ITEM NUMBER
		D930083

CABLES NOT SHOWN FOR DRAWING CLARITY

ENGINEERING USE ONLY		
DRAWING FILE	ENGINEERING MODEL NAME	MODEL TYPE
D930083	D930083	ASSEM

FARGO

RELEASED

NOT PRODUCTION VALID W/O STAMP ABOVE

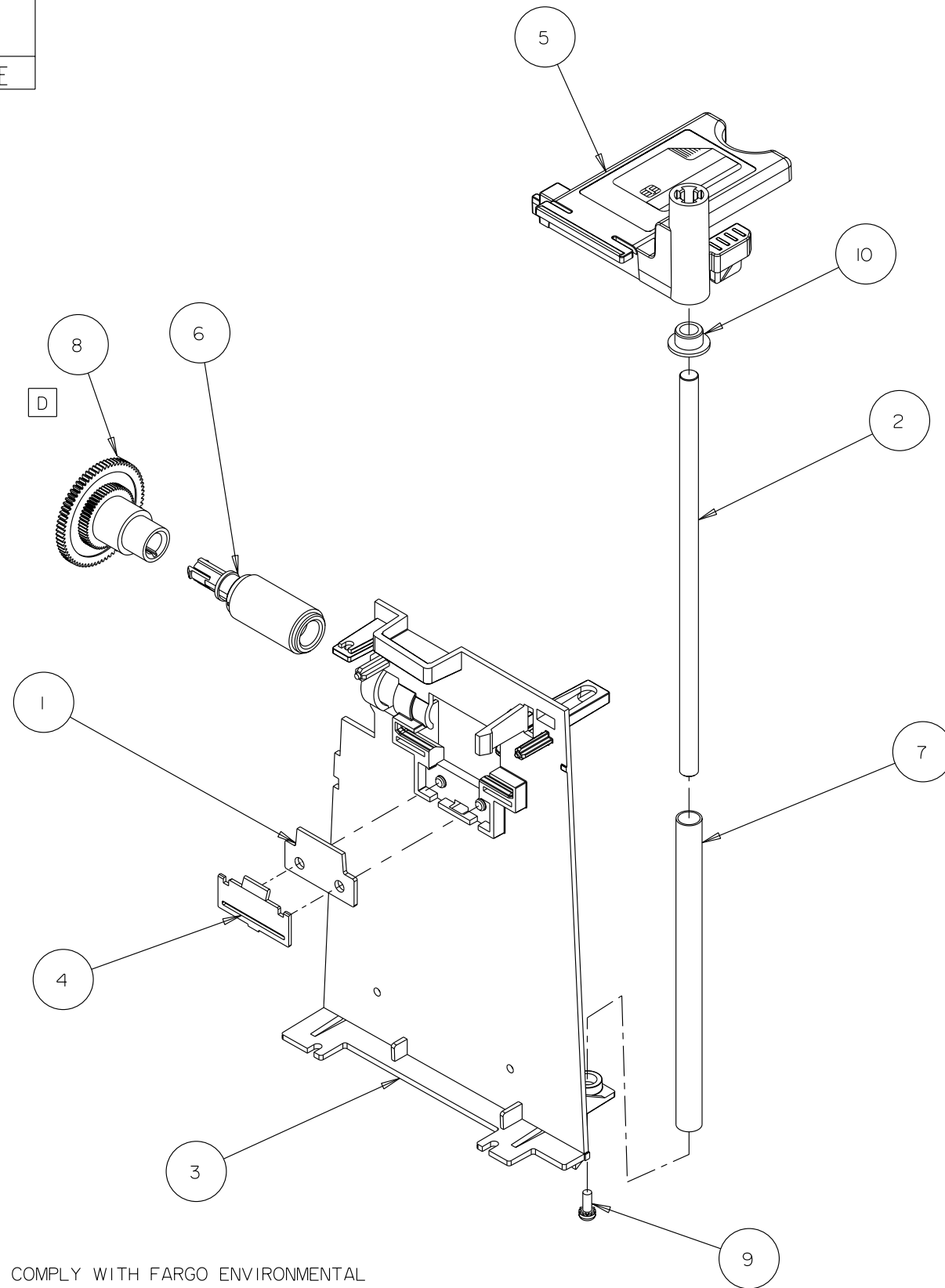

ITEM	QTY	ITEM NUMBER	TYPE	DESCRIPTION
1	1	D900576	PART	FLAP, RUBBER
2	1	D930133	PART	SHAFT-CARD INPUT
3	1	D930203	PART	BRACKET-INPUT FEED
4	1	D930204	PART	BRACKET-CARD FLAP
5	1	D930205-01	PART	BRACKET-INPUT PUSHER
6	1	D930284	ASSEMBLY	ROLLER, INPUT
7	1	D930285	PART	SPRING COMP 4.984 X .347 X .026
D	1	D930361	PART	GEAR-DRIVE
9	1	F000171	PART	SCREW-M3X8_TPH_ZP_SEM
10	1	F000350	PART	FLANGE BEARING, IGLIDE, M250

1. MATERIAL AND MANUFACTURING PROCESS MUST COMPLY WITH FARGO ENVIRONMENTAL SPECIFICATION S000503.
2. PACKAGE PER FARGO SPECIFICATION S000506.
3. ALL ELECTRONIC COMPONENTS OR COMPONENT ASSEMBLIES MUST BE MARKED WITH THE MANUFACTURERS NAME OR TRADE MARK, AND THE MANUFACTURERS TYPE CODE OR PART NUMBER. THIS INCLUDES MOTORS, FANS, SOLENOIDS, CIRCUIT BOARDS, ETC.
4. SUPPLIER CERTIFICATION OF COMPLIANCE IS REQUIRED WITH EACH SHIPMENT.

	D	REPLACED D930124 WITH D930361	C18453	13-DEC-10	DBC/ALL
	C	D930284 REV CHANGE	C17772	25-Mar-10	CJ/CJ
	B	ADDED PUR. ASY NOTES, REV CHANGE TO D930284	C17652	25-Feb-10	CJ/CJ
VER	REV	RECORD	ECO#	DATE	DRA/ENG

DRAWN BY	DATE		CONFIDENTIAL AND PROPRIETARY INFORMATION This document contains confidential and proprietary information, which may not be duplicated, published, disseminated or disclosed to unintended third party recipients (or just: "third parties") or used for any purpose, without written permission from Fargo Electronics Inc.		
	CJ 02-Nov-09				
	DIM UNITS	inch	DESCRIPTION ASY-INPUT-MECH-100 CARD		
	SCALE	0.500			
	SIZE	B	PROJECT	ASSY PART NUMBER	ITEM NUMBER
ASSY DWG				D930030	D930030

ENGINEERING USE ONLY		
DRAWING FILE	ENGINEERING MODEL NAME	MODEL TYPE
D930030	D930030	ASSEM

FARGO
RELEASED

NOT PRODUCTION VALID W/O STAMP ABOVE

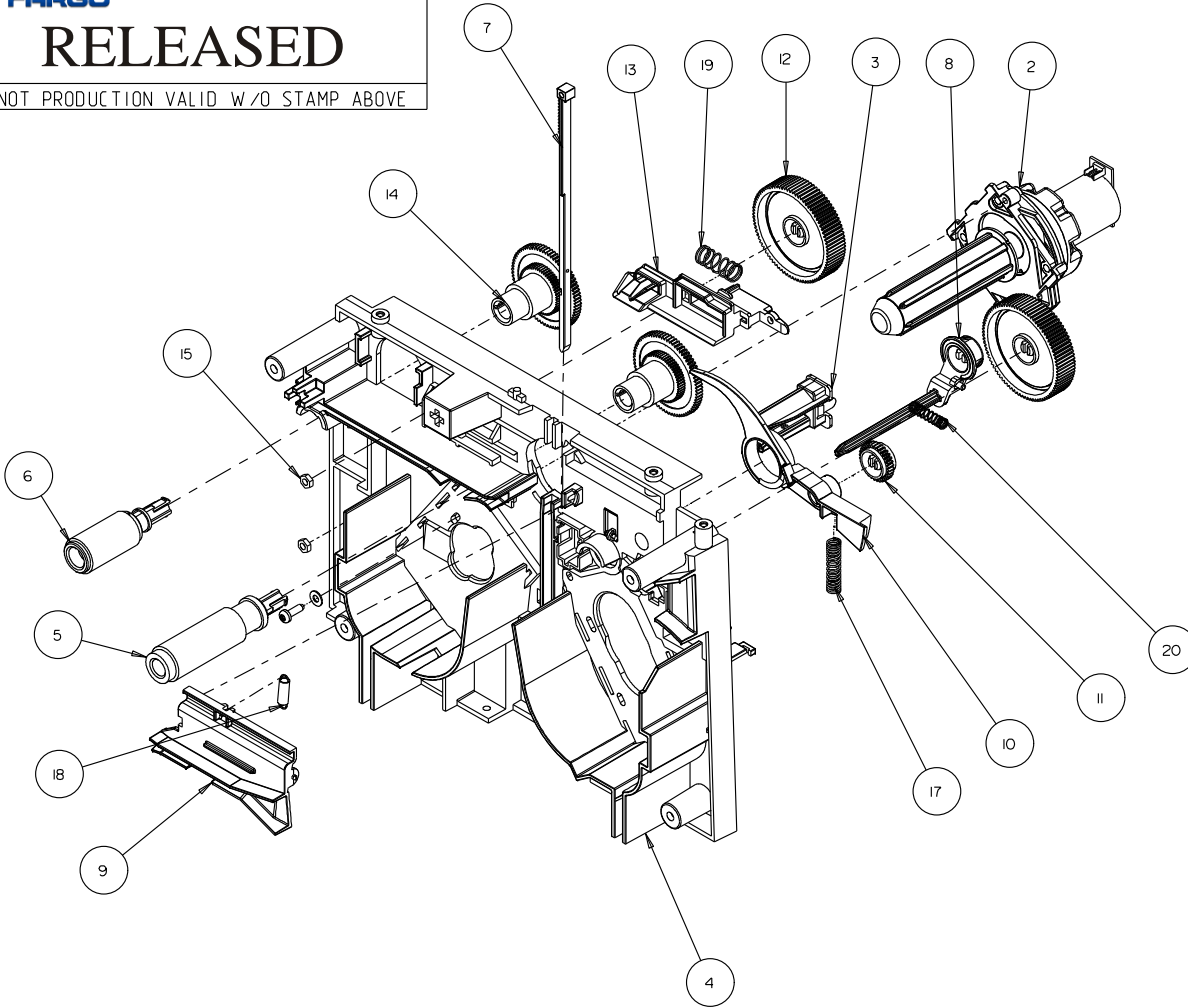

ITEM	QTY	ITEM NUMBER	TYPE	DESCRIPTION
1	1	I40040	PART	WASHER 3MM FLAT
2	1	D930014	ASSEMBLY	ASY-MOTOR-TAKEUP
3	1	D930016	ASSEMBLY	ASY-RIBBON SENSOR
4	1	D930101	PART	SIDEPLATE-REAR
5	1	D930122	ASSEMBLY	ROLLER, MAG
6	1	D930123	ASSEMBLY	ROLLER, OUTPUT
7	1	D930127	PART	PUSH ROD
8	1	D930128	PART	LEVER-CLEANING ROLLER
9	1	D930131	PART	PUSHER CARD
10	1	D930132	PART	LEVER-INPUT
11	1	D930164	PART	GEAR-INPUT_LEVER
12	2	D930209	PART	GEAR-IDLER
13	1	D930242	PART	BRACKET-SC/MAG-CAM-LINKAGE
14	2	D930361	PART	GEAR-DRIVE
15	2	F000140	PART	NUT M3 X 0.5
16	1	F000178	PART	SCREW-#4-20X.375_TPH_ZP_PLAS
17	1	F000483	PART	SPRING-COMP-1.00L x .2400D x .029WD
18	1	F000489	PART	SPRING EXT .177 X .610 X .018
19	1	F000508	PART	SPRING-COMP-.312 X .813 X .026
20	1	F000509	PART	SPRING-COMP-.180 X .750 X .020

D	REMOVED D930015, IX I40040 AND IX F000178	C18508	24-Jan-11	CJ/TL	
C	ADDED D930361	C18453	16-Dec-10	CJ/TL	
B	D930361 WAS D930124	C18269	12-Oct-10	CJ/TL	
A	INITIAL RELEASE	C18109	10-Aug-10	CJ/CJ	
VER	REV	RECORD	ECHO#	DATE	DRA/ENG

DRAWN BY CJ	DATE 30-Jul-10	<p>Part of HID Global</p>	<p>CONFIDENTIAL AND PROPRIETARY INFORMATION This document contains confidential and proprietary information, which may not be duplicated, published, disseminated or disclosed to unintended third party recipients (or just "third parties") or used for any purpose, without written permission from Fargo Electronics Inc.</p>
DIM UNITS inch	SCALE 0.100		
DESCRIPTION ASY-REAR SIDEPLATE		PROJECT ASSY DWG	ASSY PART NUMBER D930068
		ITEM NUMBER D930068	

NOTES:
1. NO CABLES ARE DISPLAYED FOR DRAWING CLARITY.

ENGINEERING USE ONLY		
DRAWING FILE	ENGINEERING MODEL NAME	MODEL TYPE
D930068	D930002_SUB2	ASSEMB